

Suspension Setup and Tuning Guide



Table of Contents

Introduction	3
Suspension Sag	4
Set Front Suspension Sag	5
Set Rear Suspension Sag	16
Front Suspension Rebound Damping	22
Front Suspension Low Speed Compression Damping	26
Front Suspension High Speed Compression Damping	29
Front Suspension Threshold	31
Front Suspension Lockout.....	32
Rear Suspension Rebound Damping	34
Rear Suspension Low Speed Compression Damping	38
Rear Suspension Threshold	41
Rear Suspension Lockout.....	42
Air Spring Bottom Out Tuning	43
Fork Models and Damper Adjustments.....	45
Rear Shock Models and Damper Adjustments.....	46
Service and Settings - Front Suspension	47
Service and Settings - Rear Suspension.....	48

Introduction

To achieve maximum suspension performance, proper setup and tuning is essential. This guide will help you identify and understand the features and adjustments that may be included on your RockShox suspension, as well as guide you through spring setup, damper adjustments and tuning, and air spring bottom out tuning.

Tuning suggestions are starting points. It may take trying various adjustments to find the settings that work best for each individual rider, bicycle, and trail condition.

Try the **Quarq ShockWiz** suspension tuning device for more detailed ride data analysis and setting suggestions. Go to www.quarq/shockwiz.com for more information.

Go to [RockShox Trailhead](#) for suggested air spring pressure and rebound damper settings for your front suspension.

Go to www.sram.com/service for additional product and technical information.

- Front suspension air spring pressure and coil spring tables are available in the *RockShox Front Suspension Oil, Air, Coil, Token, and Specification* documents.
- For a complete list of available front and rear suspension coil springs, and Bottomless Tokens and Rings, consult the *RockShox Spare Parts Catalog*.
- Consult the RockShox service manual for your suspension for complete disassembly and assembly, as well as Bottomless Token and coil spring removal and installation procedures.

Your product's appearance may differ from the images in this publication.

Setup procedures may picture the fork or rear shock only. Perform actual sag and tuning on a complete, assembled bicycle.

Performance examples illustrated are for conceptual purposes and may vary from actual performance.

Suspension Sag

Suspension sag is the percentage of full travel that the suspension compresses when the rider, including gear, is on the bicycle in a normal riding position. Setting the correct sag allows the suspension to perform effectively. Optimal suspension sag is the result of setting the proper suspension spring rate.

- **More sag** (20% - 30%) increases bump sensitivity and suspension movement. More bump sensitivity results in a smoother ride and is typically preferred on longer travel bicycles.
- **Less sag** (10% - 20%) decreases bump sensitivity and suspension movement. Less bump sensitivity results in a more firm, efficient ride and is typically preferred on shorter travel bicycles.
- **Too much sag** is an indicator that the spring rate should be increased by either increasing air spring pressure or changing the coil spring to a stiffer spring.

Air spring suspension forks: Air pressure, after sag is set, may differ from the recommended starting air spring pressure printed on your fork based on travel, bicycle geometry, and rider preference.

Important - Sag must be set before making any damping adjustments.

Sag Gradients:

Many RockShox forks and rear shocks include sag percentage gradients and a sag o-ring on one upper tube, or the rear shock body or shaft. If a sag o-ring is not on your suspension, install a plastic cable tie around the upper tube, shock body or shock shaft, just tight enough so it does not move. Remove the cable tie before riding.

If your fork or rear shock does not have sag percentage gradients, to calculate target sag, multiply the target sag percentage by the total amount of suspension travel. Use a ruler to measure the length of exposed upper tube, damper body or shock shaft above the wiper seal to the sag o-ring.

If your suspension's travel is unknown, before sag is measured, fully compress the suspension to bottom out. Release and use a ruler to measure the length of exposed upper tube, damper body, or shock shaft below the sag o-ring or stopping point of the wiper seal.

Getting started:

Front suspension air pressure recommendations listed on the back of your fork, and at [RockShox Trailhead](#), are suggestions for initial spring setup. Front suspension coil springs are available in a number of spring rates ranging from soft to extra firm. Refer to the *Front Suspension Oil, Air, Coil, Token and Specifications* document for coil spring recommendations based on rider weight.

Rear shocks are available with an air spring or coil spring. Due to the specificity of frame designs, it is best to follow the [Set Rear Suspension Sag](#) procedure to determine the correct spring rate. Rear shock coil springs are available in a number of spring rates based on the eye-to-eye shock length and compression stroke dimensions of your shock. Refer to the *RockShox Spare Parts Catalog* for available springs.



Set Front Suspension Sag

Open Dampers



Before setting sag, set the dampers to the full open positions. Rotate the adjusters counter-clockwise until they stop.

Remote: Set the compression damper to the open position.

Air Spring - Solo Air, DebonAir, Dual Position Air



Pressurize the air spring to the recommended starting air pressure.

Remove the pump. Do not compress the suspension with the pump attached.

Dual Position Air only: Pressurize the fork in the full travel position. Proceed to [step 6](#).

Solo Air and DebonAir only: Compress the fork through at least 50% of its travel five times to equalize positive and negative air pressures.

Air pressure equalization ensures the positive air spring is accurately pressurized.

Pressurize the air spring to the recommended starting pressure once more.

Remove the pump. **Do not compress the suspension with the pump attached.**



Solo Air and DebonAir only: Compress the fork through at least 50% of its travel five more times to equalize positive and negative air pressures.



With riding gear on, and an assistant holding the bike, stand on the pedals, and compress the fork three times. Then sit or stand in your normal riding position.



Have your assistant slide the sag o-ring down to the top of the dust wiper seal.

8 ↑



Gently step off the bicycle without compressing the fork any further.

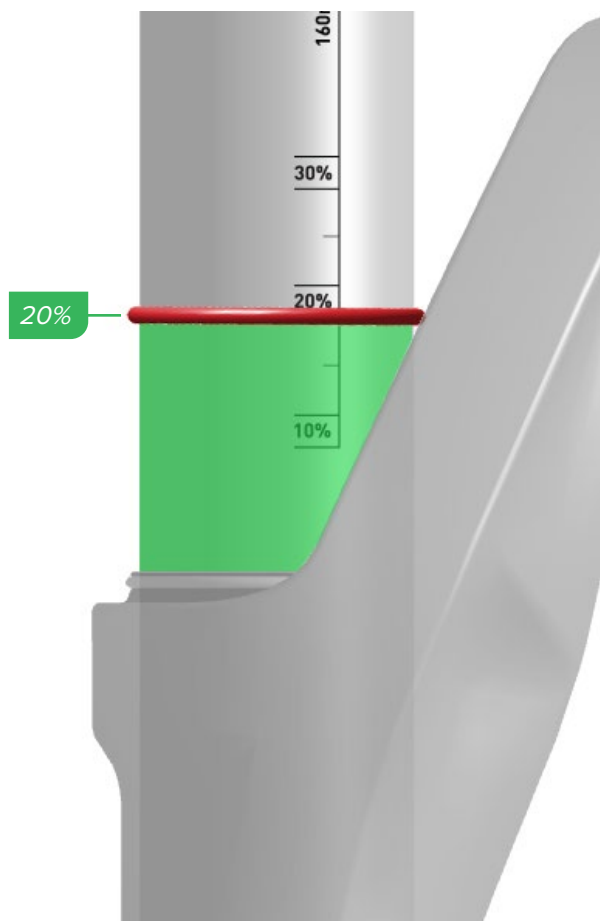

Note the sag percentage where the o-ring stopped.

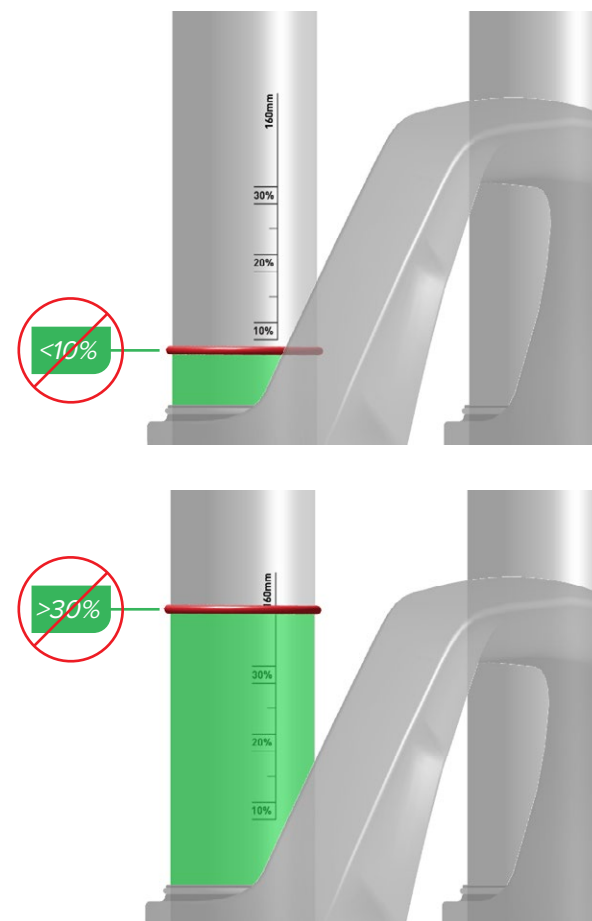

If your [target sag](#) percentage is not achieved, air pressure must be adjusted.

Increase air pressure to **decrease** sag.

Decrease air pressure to **increase** sag.

Repeat the sag process until your target sag percentage is achieved.

Coil Spring - Preload Spacers



With riding gear on, and an assistant holding the bike, stand on the pedals, and compress the fork three times. Then sit or stand in your normal riding position.

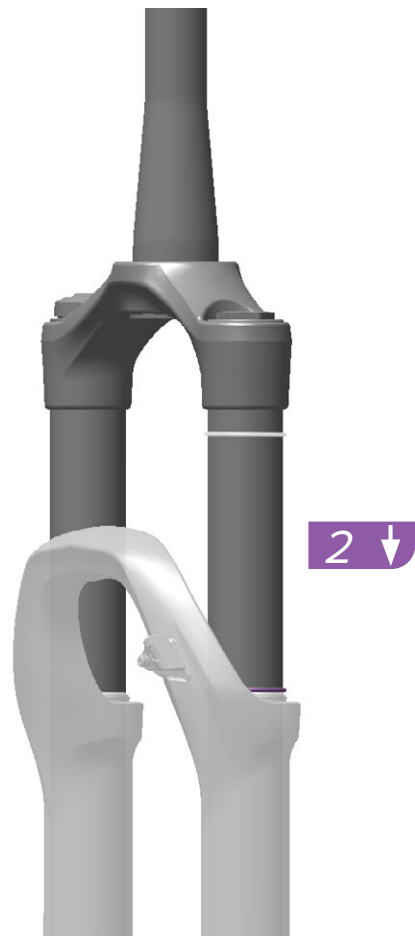

Have your assistant slide the sag o-ring down to the top of the dust seal.

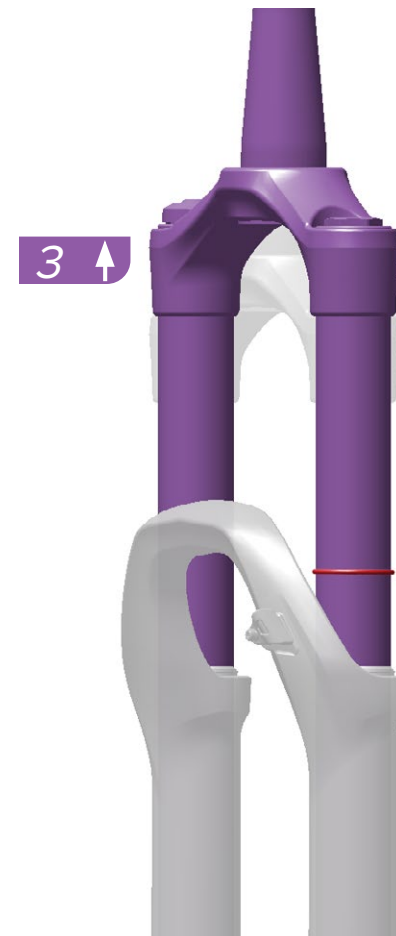

Gently step off the bicycle without compressing the fork any further.

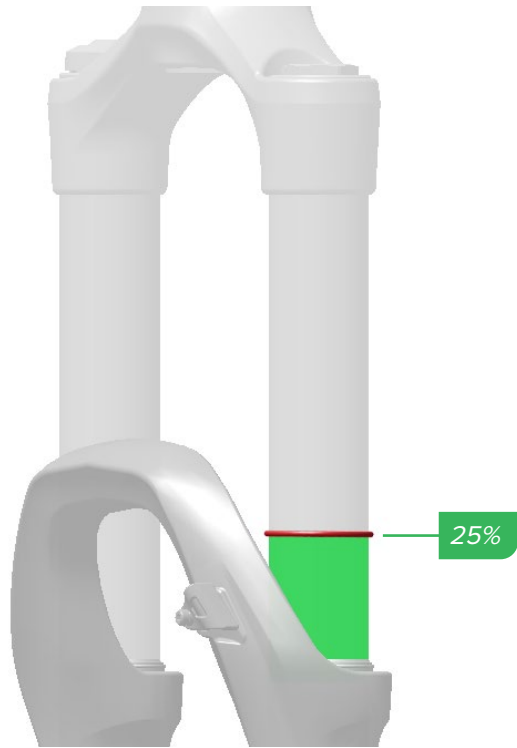

Note the sag percentage where the o-ring stopped.

If your [target sag](#) percentage is not achieved, spring preload adjustment and/or coil spring replacement must be performed.

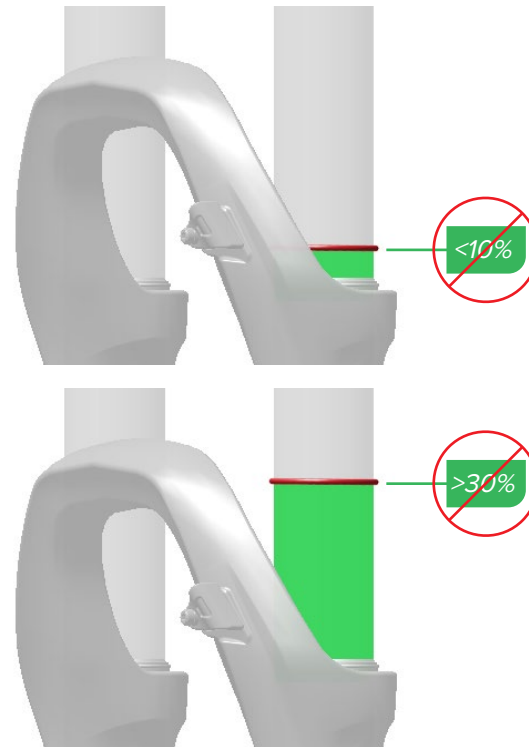

Preload spacers compress or decompress the spring without initiating travel.

The coil spring can be preloaded with the maximum number of preload spacers specified for the fork model. Refer to the Service Manual for your fork for more information.

Remove preload spacers to **decrease** preload and **increase** sag.

Install preload spacers to **increase** preload and **decrease** sag.

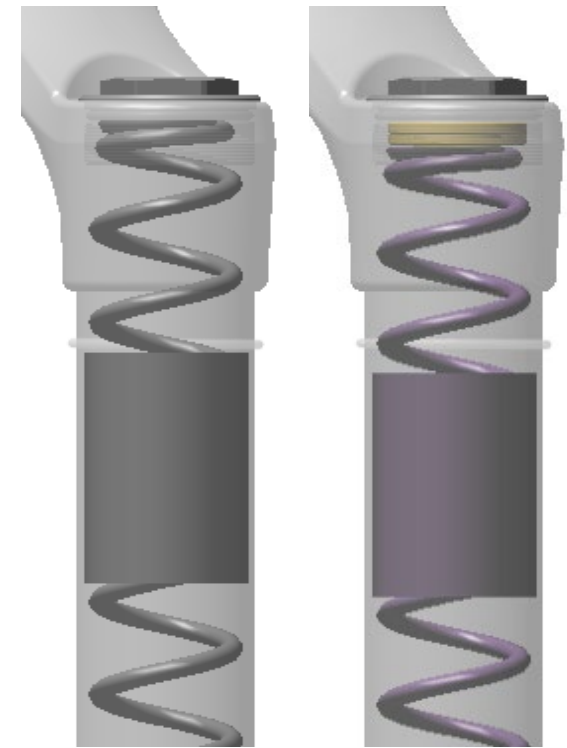

Spring preload can be used to fine tune sag, but preload does not change coil spring rate and is not a substitute for the proper coil spring.

If your [target sag](#) cannot be achieved with the maximum number of preload spacers, replace the coil spring with a firmer spring.

If your target sag cannot be achieved with zero preload spacers, replace the coil spring with a softer spring.

Repeat the sag process until your target sag percentage is achieved.

Coil Spring - External Preload Adjuster Knob



Turn the preload adjuster knob counter-clockwise until it stops.
This is the least amount of spring preload, or the softest setting.



With riding gear on, and an assistant holding the bike, stand on the pedals, and compress the fork three times. Then sit or stand in your normal riding position.

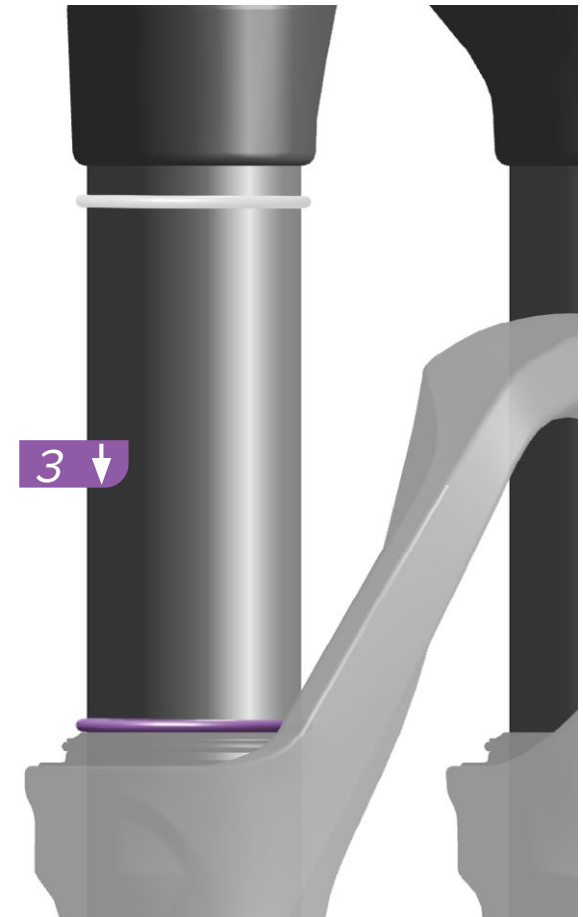

Have your assistant slide the sag o-ring down to the top of the dust seal.



Gently step off the bicycle without compressing the fork any further.

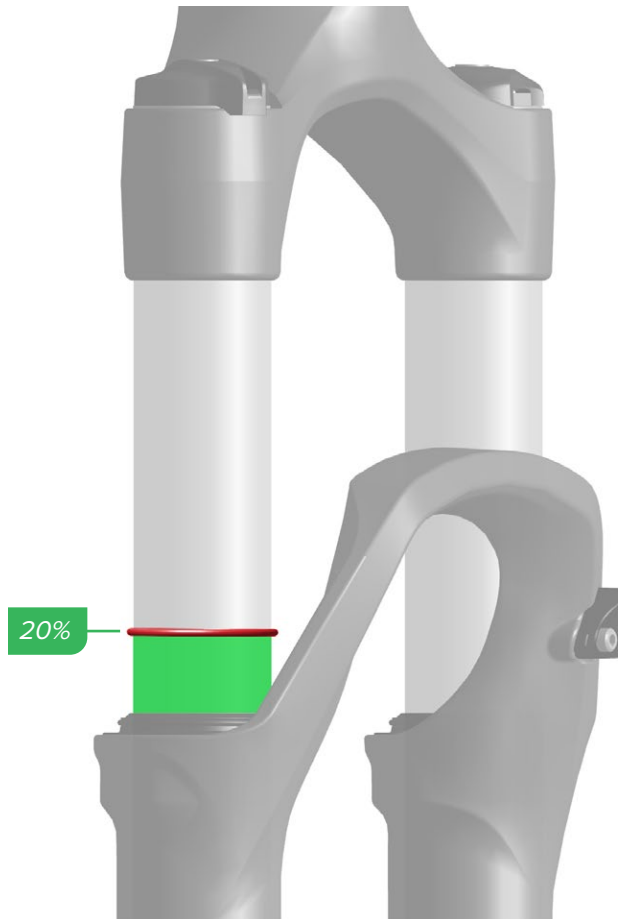

Note the sag percentage where the o-ring stopped.

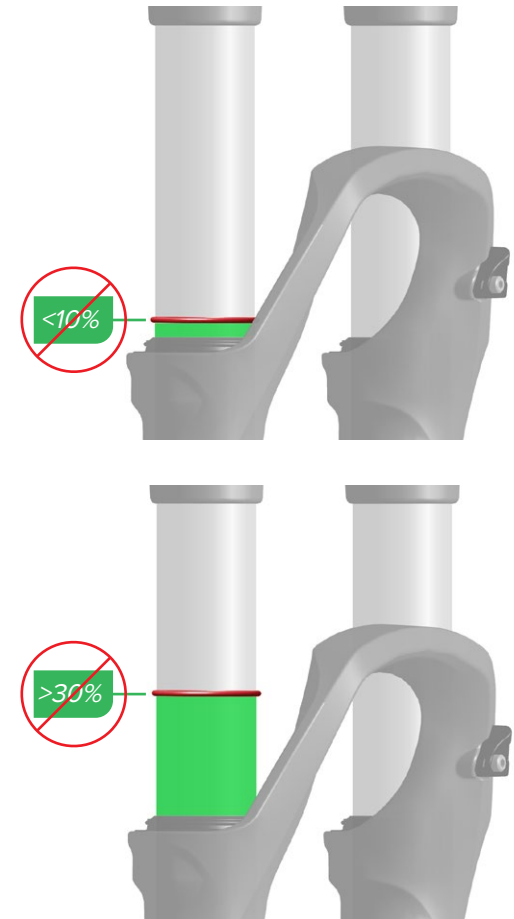

If your [target sag](#) percentage is not achieved, spring preload adjustment and/or coil spring replacement must be performed.



External spring preload adjustment compresses or decompresses the spring without initiating travel.

Turn the preload adjuster knob **clockwise** to **increase** spring preload and **decrease** sag.

Turn the preload adjuster knob **counter-clockwise** to **decrease** spring preload and **increase** sag.



Spring preload adjustment can be used to fine tune sag, but preload does not change spring rate and is not a substitute for the proper coil spring weight.

If the proper sag cannot be achieved after external preload adjustment, the coil spring assembly must be replaced with a softer or firmer spring.

To **increase** sag, install a **softer** coil spring assembly.

To **decrease** sag, install a **firmer** coil spring assembly.

Repeat the sag process until your target sag percentage is achieved.

Coil Spring - Paragon Silver



With riding gear on, and an assistant holding the bike, stand on the pedals, and compress the fork three times. Then sit or stand in your normal riding position.

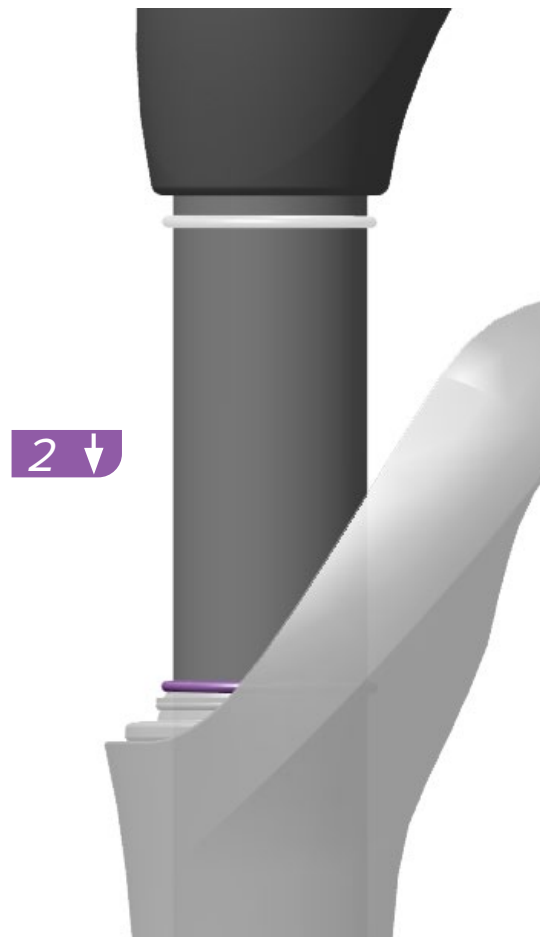

Have your assistant slide the sag o-ring down to the top of the dust seal.



Gently step off the bicycle without compressing the fork any further.

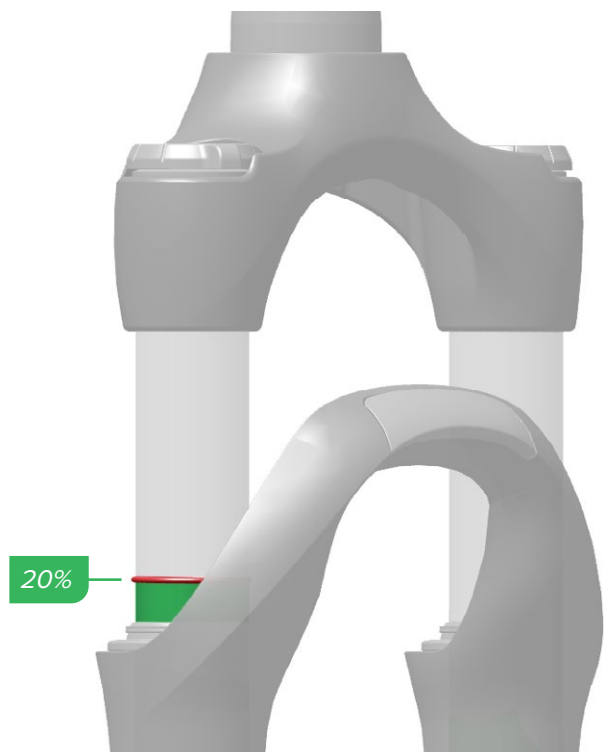

Note the sag percentage where the o-ring stopped.

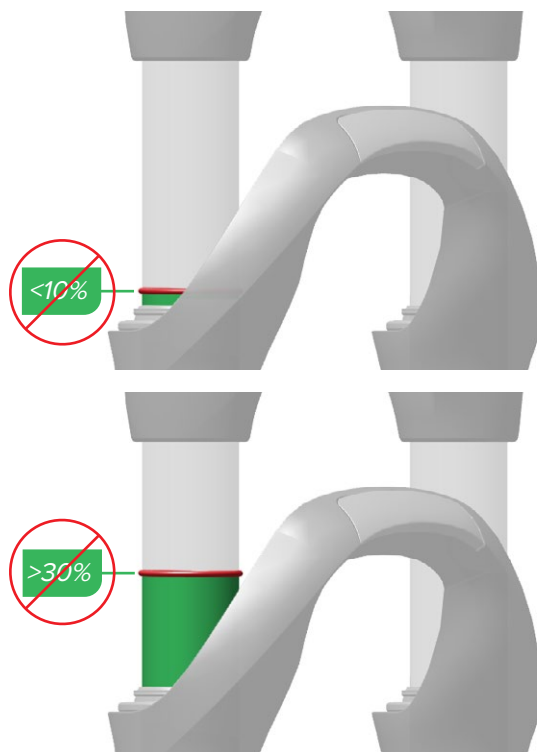

If your [target sag](#) percentage is **not** achieved, spring preload adjustment must be performed.

Coil spring preload in RockShox Paragon is an internal adjustment that compresses or decompresses the spring without initiating travel.

The coil spring can be preloaded 5 mm or 10 mm with the internal preload spacer.

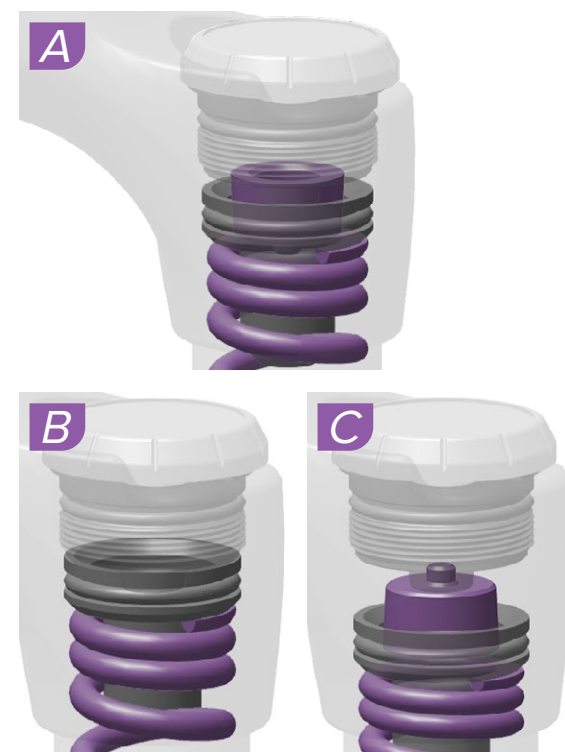

Remove the top cap to remove or re-orient the internal preload spacer.

A) Standard 5 mm (factory installed) preload spacer orientation.

B) To **decrease** preload and **increase** sag, **remove** the preload spacer.

C) To **increase** preload and **decrease** sag, **reorient** the preload spacer to the 10 mm preload position.

Repeat the sag process until your target sag percentage is achieved.

Set Rear Suspension Sag

Air Spring - Solo Air, DebonAir

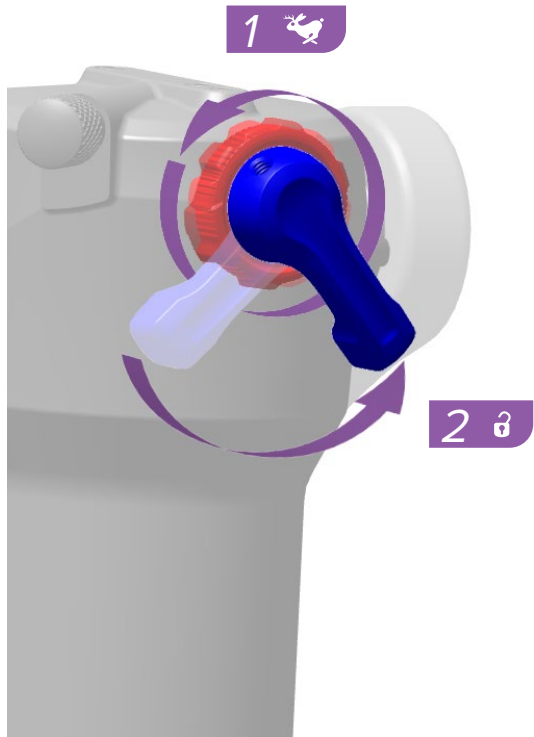

Before setting sag, set the dampers to the full open positions. Rotate the adjusters counter-clockwise until they stop.

Remote: Set the shock to the open position.



Beginning with the shock fully deflated, pressurize the air spring chamber to 100 psi.

Remove the pump. **Do not compress the suspension with the pump attached.**



Fully compress the shock five times to equalize the positive and negative air springs.



Pressurize the shock (PSI) to the equivalent of the rider's total weight (lbs), including riding gear.

Remove the pump. **Do not compress the suspension with the pump attached.**

Example: 160 lbs = 160 PSI



Compress the shock once more to equalize air pressure.



With riding gear on, and an assistant holding the bike, step onto the bicycle and lightly cycle the shock two to three times while in the standing position on the pedals.

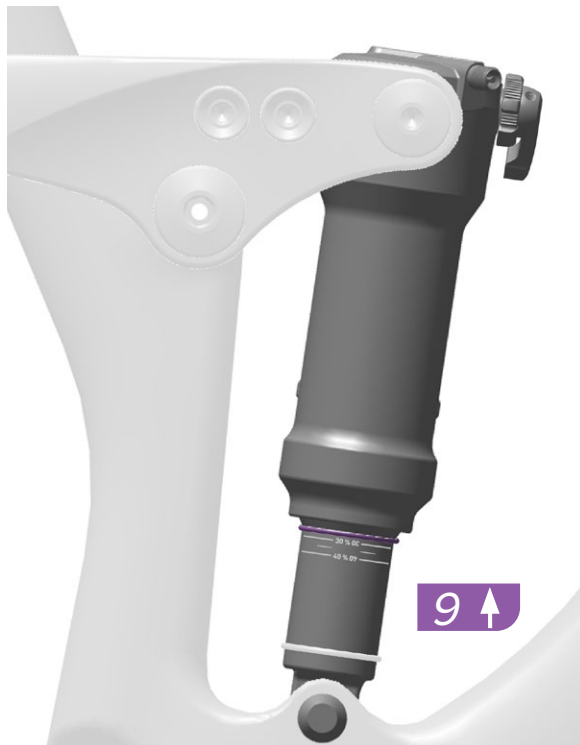

While seated on the bicycle, have an assistant slide the sag o-ring against the wiper seal.



Gently step off the bicycle without compressing the shock.

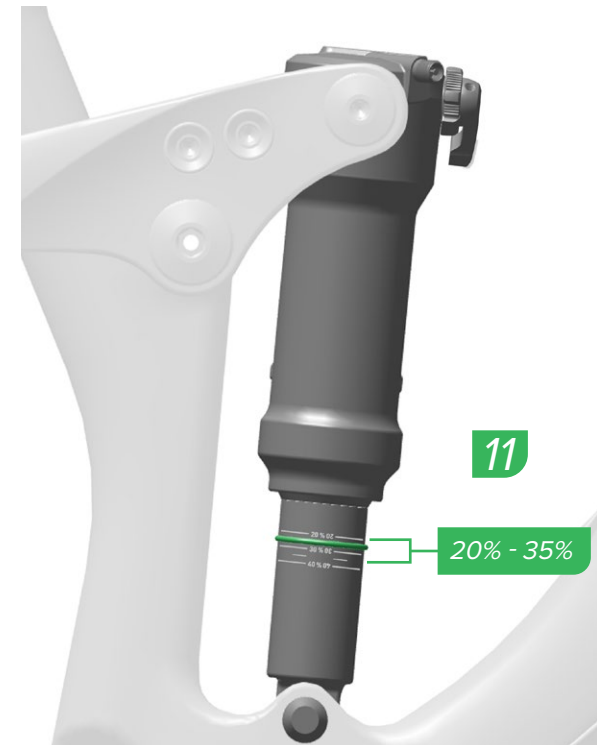

Note the sag percentage where the o-ring stopped.

Correct sag percentage for Solo Air shocks is ~25%. Correct sag percentage for DebonAir shocks is ~30%.

Sag can be set $\pm 5\%$ as preferred.

If your [target sag](#) percentage is **not** achieved, air pressure must be adjusted.

Increase air pressure to **decrease** sag.

Decrease air pressure to **increase** sag.

Coil Spring

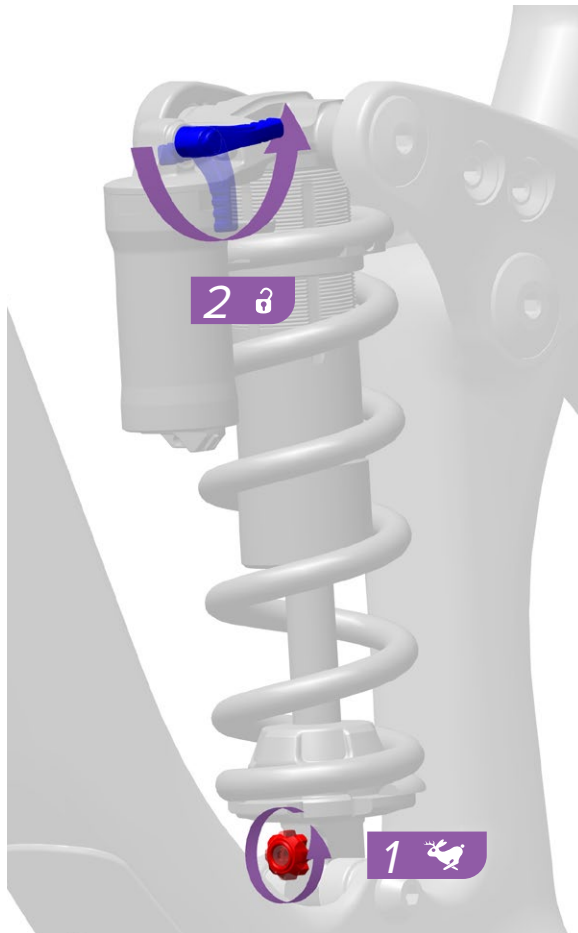

Before setting sag, set the dampers to the full open positions. Rotate the adjusters counter-clockwise until they stop.

Remote: Set the shock to the open position.



Turn the spring preload adjuster counter-clockwise until there is no resistance.



Turn the spring preload adjuster clockwise two full turns.

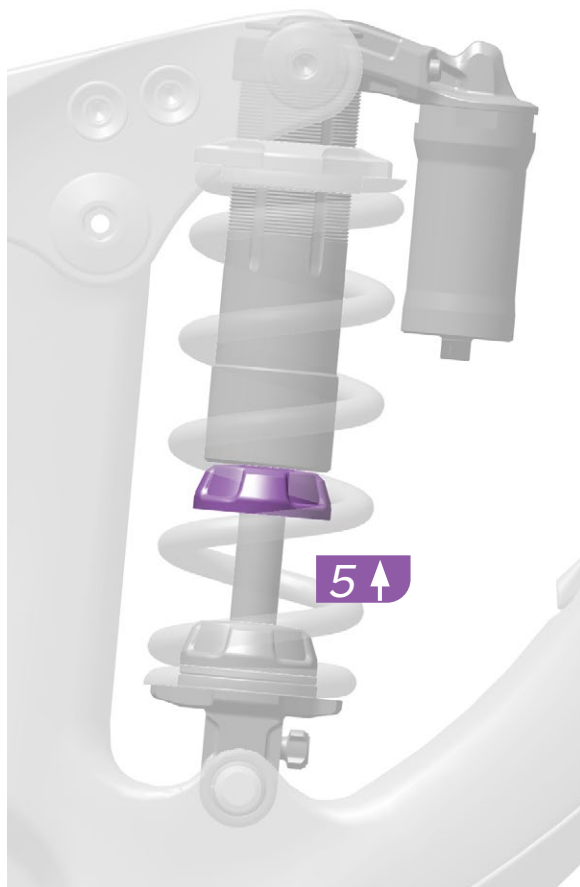

Slide the bottom out bumper to the shock body.

⚠ CAUTION

To avoid injury, use a non-metallic tool to slide the bumper. **Do not use your finger.**



With riding gear on, and an assistant holding the bike, step onto the bicycle and lightly cycle the shock two to three times while in the standing position on the pedals.



While seated on the bicycle, have an assistant slide the bottom out bumper against the wiper seal.

⚠ CAUTION

To avoid injury, use a non-metallic tool to slide the bumper. **Do not use your finger.**



Gently step off of the bicycle without compressing the rear shock.

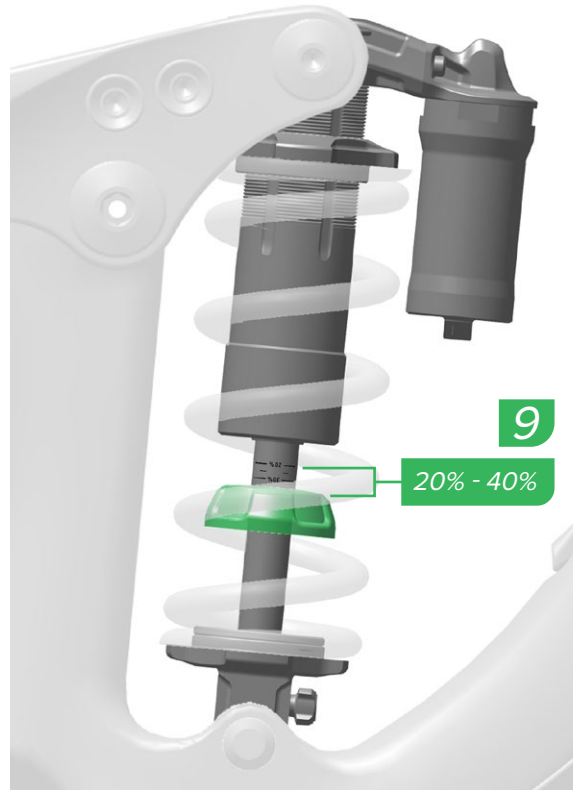

Check the top of the bottom out bumper position on the shock shaft and note the sag percentage.

If the shaft does not include sag gradients, measure the shaft length with a ruler.

Sag should be between 20% and 40%.



If your [target sag](#) percentage is **not** achieved, turn the preload adjuster ring and repeat the measuring process until the desired sag value is achieved.

If the sag value is not at the desired level after **five** full clockwise turns, a heavier spring must be installed, and the sag setting procedure must be repeated.

NOTICE

Do not exceed five full turns of preload adjustment.

Front Suspension Rebound Damping

Rebound damping controls suspension fork extension/return speed which affects traction and control.

Optimal rebound damping allows the fork to extend at a controlled speed and maintain traction and control.

Rebound that is too fast allows the fork to extend too quickly which causes the wheel to bounce off of objects and the ground resulting in a 'pogo' effect.

Rebound that is too slow prevents the fork from extending quickly enough to regain contact with the ground or prepare for the next impact.

Rebound damping can be tuned to rider weight, spring rate and travel, as well as for terrain and rider preference.

As air pressure or spring rate increases, extension/return speed increases. To achieve the optimal setting, rebound damping may need to be increased when air pressure or spring rate increases.

For recommended rebound settings refer to [RockShox Trailhead](#). After setting [sag](#), adjust the rebound damper, go for a test ride, and adjust again as preferred.



To **decrease** rebound speed (slower return), turn the rebound adjuster **clockwise**.



To **increase** rebound speed (faster return), turn the rebound adjuster **counter-clockwise**.

Optimal

- A** The fork rebounds at a controlled speed and the wheel maintains contact with the ground.
- B** The fork crown, handlebars, and rider are more level with the ground over each bump. Suspension movement is predictable and controlled.

Adjustment:
No adjustment is needed.

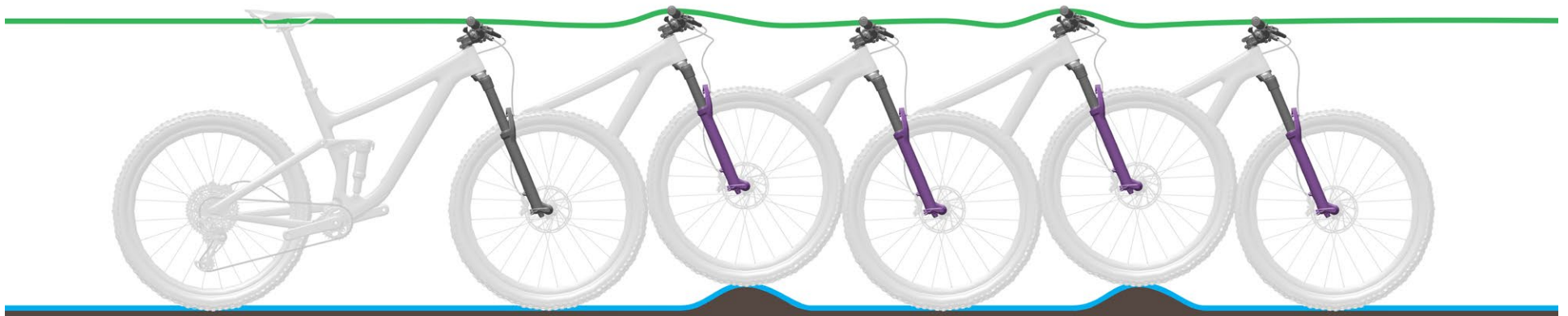

Too Fast

- A** The fork rebounds too quickly causing a 'pogo' effect where the wheel bounces off of the terrain unpredictably. Traction and control are decreased.
- B** The fork crown and handlebars are forced upward after the wheel bounces off of the ground. Rider weight may shift upward and back uncontrollably.

Adjustment:

Turn the rebound adjuster **clockwise** to **decrease** rebound speed, and increase traction and control.

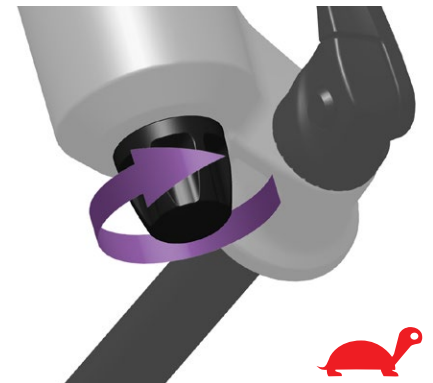

Too Slow

A The fork does not extend quickly enough after absorbing a bump. The fork stays compressed through successive bumps, reducing travel and increasing impact firmness. Available travel, traction and control are decreased.

B The fork stays in a compressed state which puts the crown and handlebars in a lowered position. Rider weight may shift forward at impact.

Adjustment:

Turn the rebound adjuster knob **counter-clockwise** to **increase** rebound speed and improve bump performance.

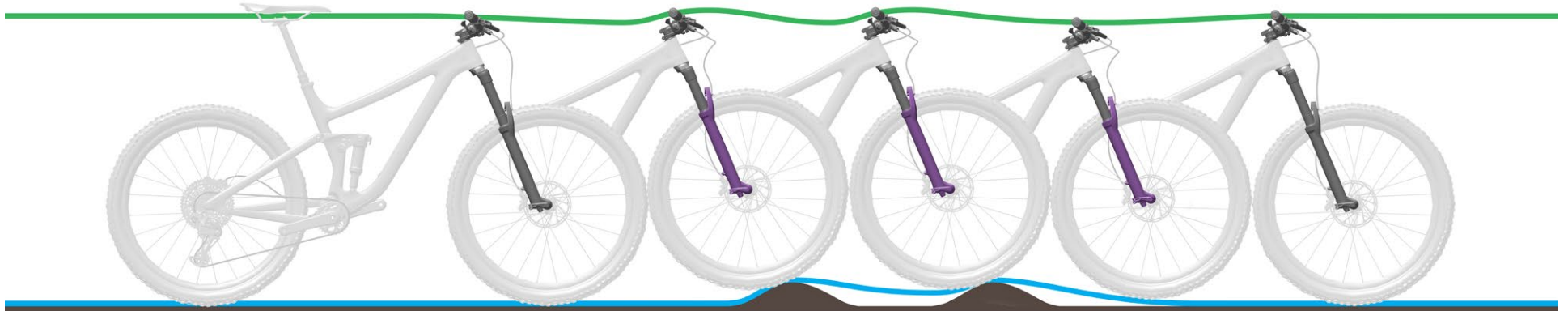

Front Suspension Low Speed Compression Damping

Low speed compression (LSC) damping adjustment controls compression stroke speed, or the rate at which the fork compresses, during slow compression stroke scenarios. LSC affects bump absorption and efficiency during rider weight shifts, transitions, cornering, more gradual bump impacts, and braking.

Increased LSC damping:

- Keeps the suspension fork riding higher in its travel. This may help the rider improve efficiency and maintain momentum over gradual, rolling terrain and through corners.
- Suspension compression may feel more firm on bumpier terrain.

Decreased LSC damping:

- Allows the fork to compress quickly and easily. This may help the rider maintain momentum and speed on bumpier terrain.
- Suspension compression may feel less firm on bumpier terrain.

LSC damping adjustments have less effect during high speed compression stroke scenarios. Drops and large bump impacts can exceed the LSC damper's effective range of control and will cause the suspension fork to compress suddenly and quickly, regardless of the LSC damper setting.

Increase LSC damping to reduce compression stroke speed and increase efficiency on rolling or smoother terrain, and when frequently climbing out of the saddle.

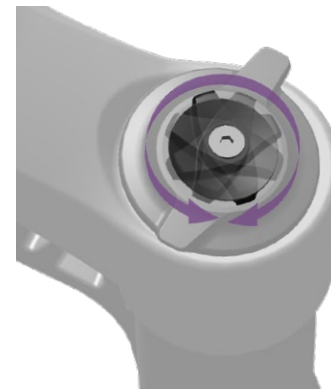

RLC / RCT3

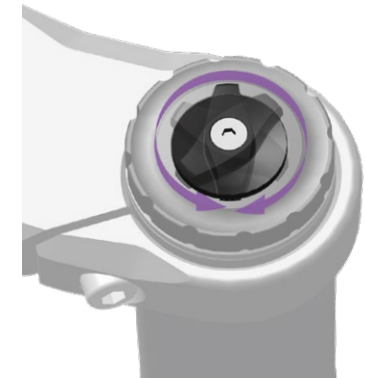

RC2



RC / RL

To **increase** (+) low speed compression damping (firm), turn the compression adjuster knob **clockwise**.

To **decrease** (-) low speed compression damping (soft), turn the compression adjuster knob **counter-clockwise**.

Rolling Terrain

Low Speed Compression Damping - Open / Too Soft

The fork compresses at the low point of the terrain. Suspension travel is used quickly, the rider's weight may shift forward, and bicycle momentum may be reduced.

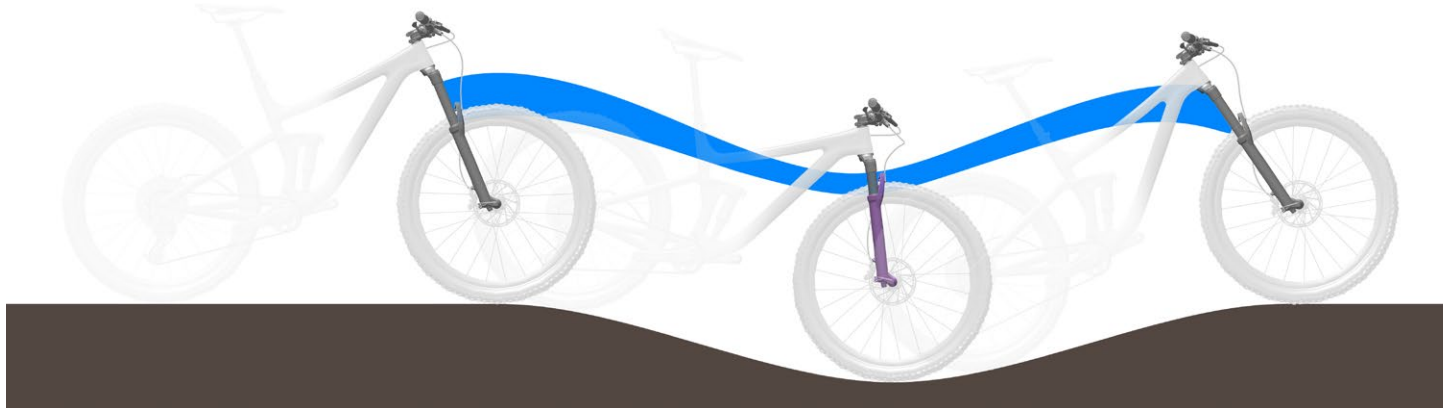

Low Speed Compression Damping - Mid to Firm

The fork resists compressing, remains higher in its travel, and helps the rider maintain speed into and through the rolling section of terrain.

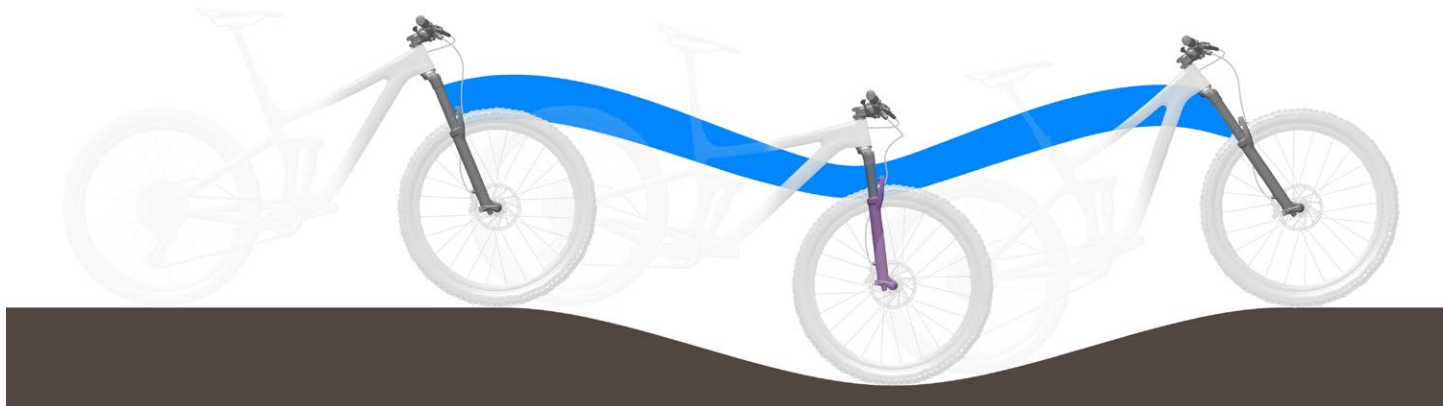

Adjustment:

To improve efficiency on rolling and smoother terrain, rotate the LSC or compression adjuster knob **clockwise** to **increase** compression damping and firmness, and **decrease** compression stroke speed.

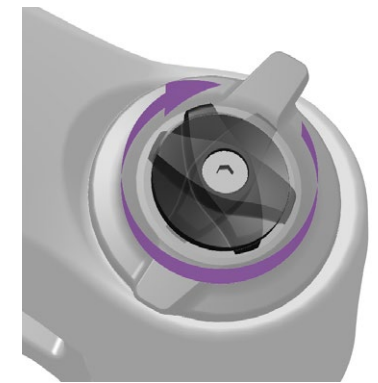

Bumps

Low Speed Compression Damping - Soft to Mid

- A** At bump impact, the fork compresses quickly and freely, and the bump is absorbed. Traction is maintained.
- B** The fork reacts quickly to the impact. The crown and handlebar rise slightly as the bump is absorbed.



Low Speed Compression Damping - Too Firm

- A** At bump impact, the fork compresses too slowly and the wheel deflects off of the bump. Traction is decreased as the wheel leaves the ground.
- B** The crown and handlebar are forced upward significantly, which can decrease control.



Adjustment:

To **increase** small bump sensitivity rotate the LSC or compression adjuster knob **counter-clockwise** to **decrease** compression damping and firmness, and **increase** compression stroke speed.

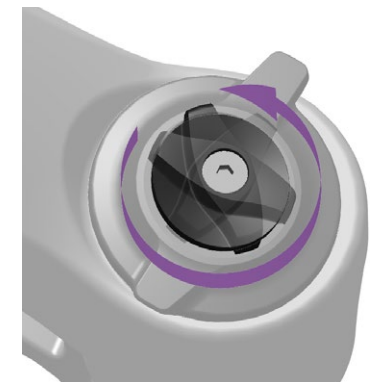

Front Suspension High Speed Compression Damping

High Speed Compression (HSC) damping adjustment controls compression stroke speed, or the rate at which the fork compresses, during quick compression scenarios. HSC affects bump impact absorption and efficiency over large and square edge bumps, and down drops.

Bump size and shape, as well as riding speed, can affect compression stroke speed. Large or square edge/sharp bumps will cause the fork to compress suddenly and quickly. Impacts of any size and shape will compress quicker when impacted at increased riding speed.

Increased HSC damping:

- Suspension travel used on bumpier terrain may be limited and may vary depending on bump or drop size. This can prevent premature bottom out when riding over and through larger impacts.
- Suspension compression may feel more firm on bumpier terrain.

Decreased HSC damping:

- Allows the suspension to compress easily at higher compression stroke speeds. This may help the rider maintain speed and momentum on moderately bumpy terrain.
- May allow quick bottom out when riding quickly over and through larger bumps and drops.
- Suspension compression may feel less firm on bumpier terrain.

HSC damping adjustments have less effect during low speed compression stroke scenarios. Rider weight shifts, transitions, cornering, more gradual impacts, and braking do not create enough force to enter the HSC damper's effective range of control.

Increase HSC damping to reduce high speed compression stroke speed on moderate to larger impacts and very aggressive terrain.

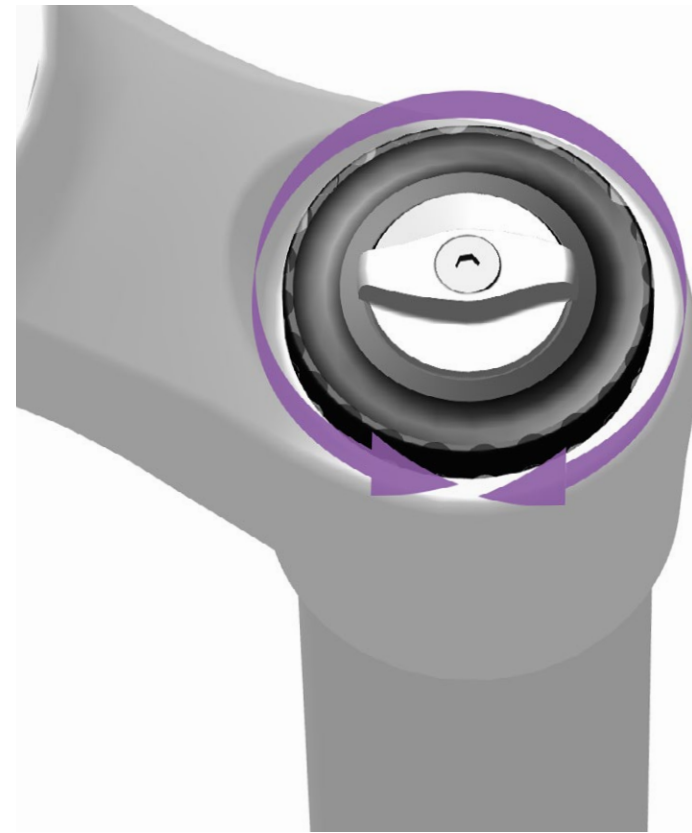

RC2

To **increase** (+) high speed compression damping (firm), turn the HSC adjuster knob **clockwise**.

To **decrease** (-) high speed compression damping (soft), turn the HSC adjuster knob **counter-clockwise**.

Square Bumps and Drops

HSC Damping - Soft

- A** The fork compresses through full travel quickly and freely. The fork can use most of its travel as impacts are fully absorbed.
- B** The fork crown and handlebar drop quickly at full compression, or fork bottom out.

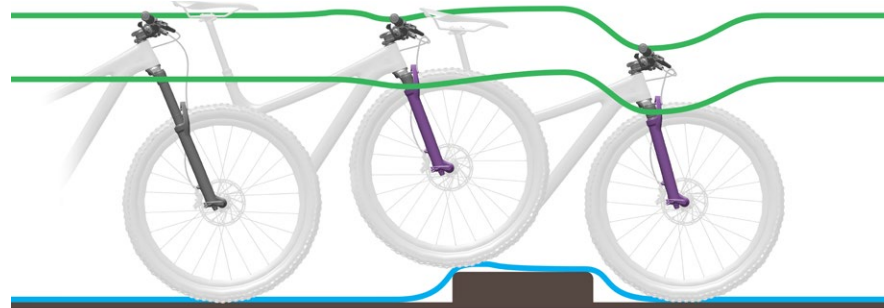

HSC Damping - Mid

- A** The fork can compress through its effective travel, absorbing the impact in a controlled manner. Use of full travel may depend on rider speed and bump size.
- B** The fork crown and handlebar rise moderately at bump impact, and drop moderately after the drop.

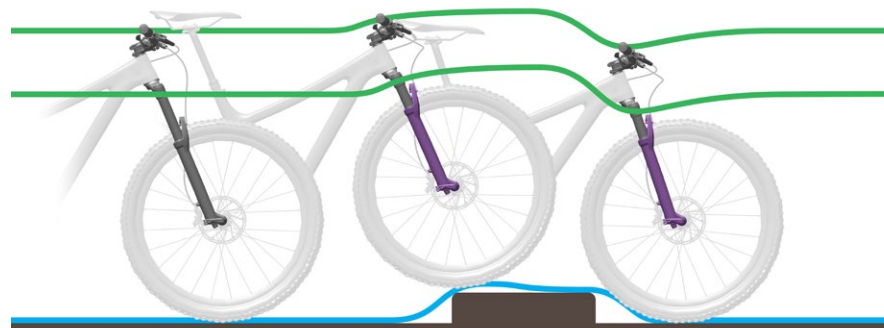

HSC Damping - Firm

- A** The fork can resist compressing and impact force may be transmitted to the rider. The fork compresses partially and does not bottom out. Use of full travel depends on rider speed and bump size.
- B** The fork crown and handlebar are suddenly forced up at bump impact, and drop minimally after the drop as the fork resists compressing.

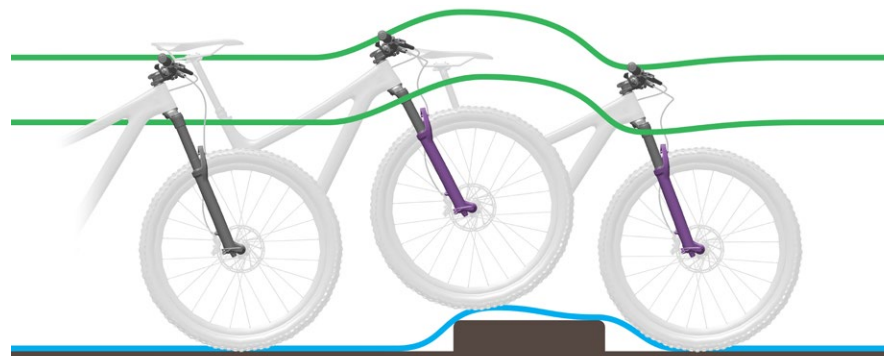

Adjustment:

Rotate the HSC adjuster knob **counter-clockwise** to **decrease** compression damping and **increase** stroke speed.

Rotate the HSC adjuster **clockwise** to **increase** compression damping and **decrease** stroke speed.

Start with a **mid** setting and adjust as desired. Larger bumps and drops, and increased riding speed will typically allow for a firmer HSC setting.

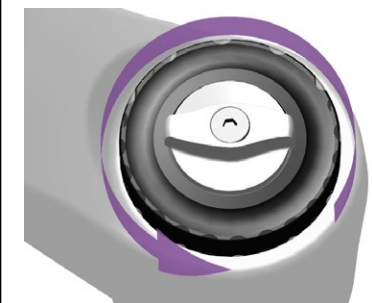
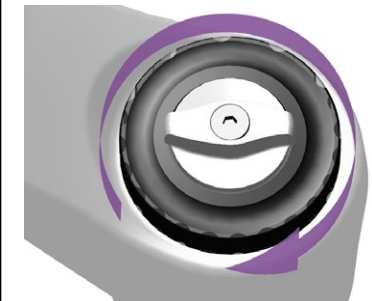

Front Suspension Threshold

Threshold (T) mode prevents the suspension fork from compressing until moderate bump impact or downward force occurs. Threshold mode increases efficiency on smoother terrain.

Use the Threshold setting to increase pedaling efficiency on flat, rolling, smooth, or moderately bumpy terrain. When in Threshold mode, increased bicycle speed will increase bump impact force causing the fork to compress and absorb the bump.

- When the adjuster knob is in the (A) Open position (full counter-clockwise) the suspension fork will compress quickly and freely through its full range of travel when bump impact or downward force occurs.
- When the adjuster knob is in the (B) Threshold position the suspension fork will resist compressing until **moderate** bump impact or downward force occurs.
- When the adjuster knob is in the (C) Lock position (full clockwise) position the suspension fork will resist compressing into its travel until **significant** bump impact or downward force occurs.

To activate Threshold, rotate the knob to the Threshold position.

Threshold on forks equipped with a remote can be actuated with the handlebar mounted remote at any time during use. Refer to the appropriate remote user manual at www.sram.com/en/rockshox/products/remotes for more information.

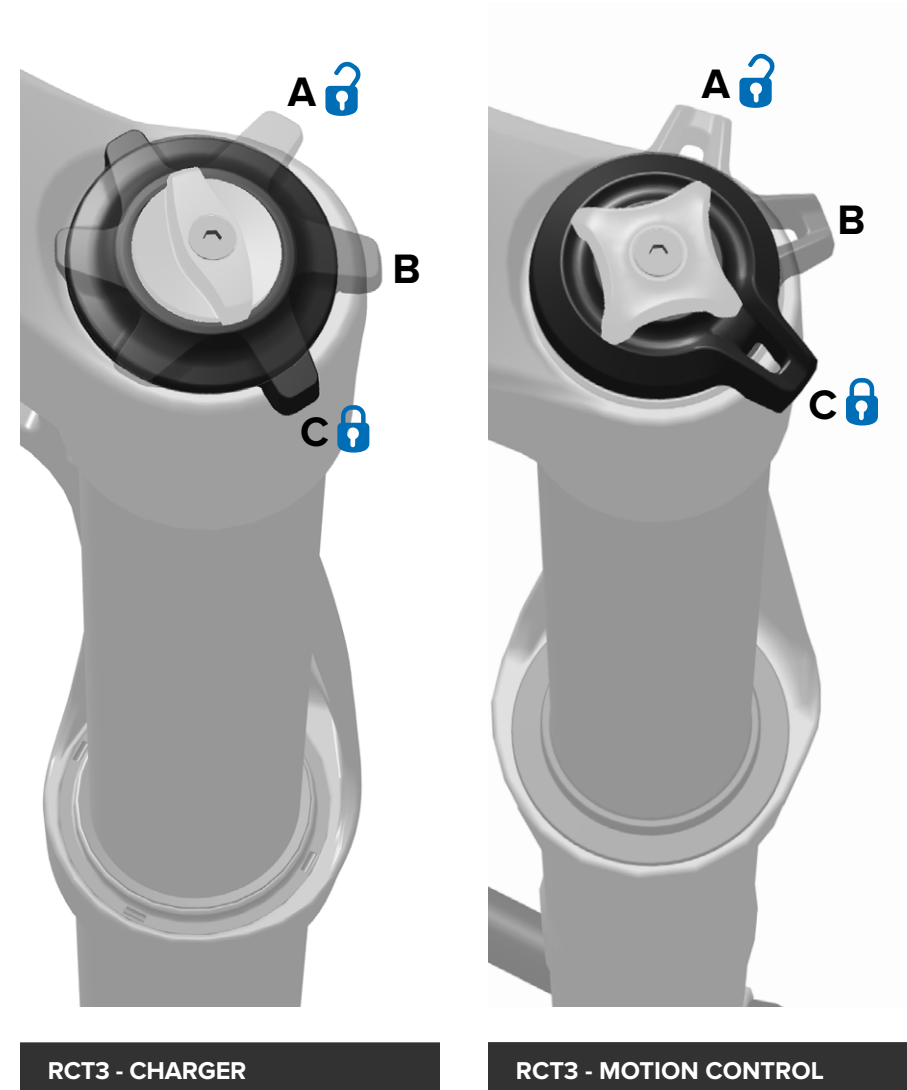

Front Suspension Lockout

Lockout (L) mode prevents the suspension fork from compressing. Use Lockout mode for maximum pedaling efficiency on smoother terrain.

- When the Lockout adjuster is in the (A) **Open** position (full counter-clockwise) the suspension fork is able to compress quickly and freely through its full range of travel.
- When the Lockout adjuster is in the (B) **Lock** position (full clockwise) position the suspension fork will resist compressing into its travel until significant bump impact or downward force occurs.

To activate Lockout mode, rotate the adjuster clockwise until it stops.

To deactivate Lockout mode, rotate the adjuster counter-clockwise.

Lockout on forks equipped with a remote can be actuated with the handlebar mounted remote at any time during use. Refer to the appropriate remote user manual at www.sram.com/en/rockshox/products/remotes for more information.

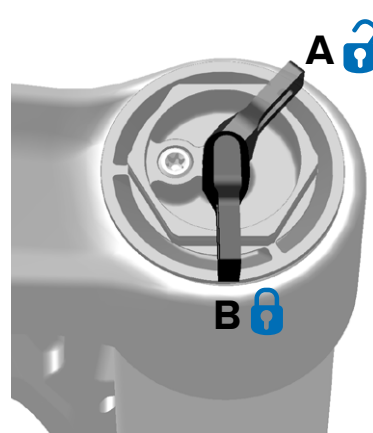

CHARGER RACE DAY



RCT3

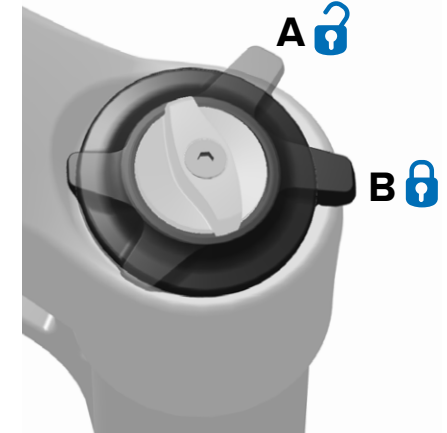

RLC

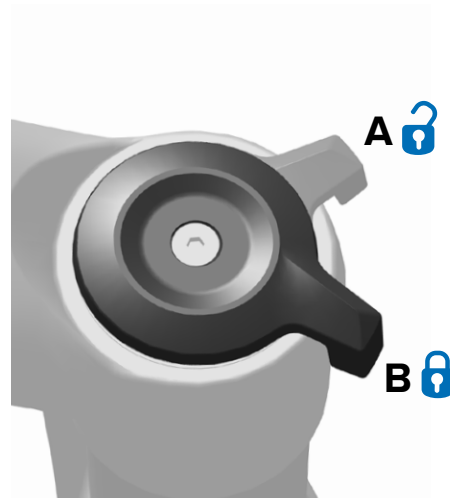

RL

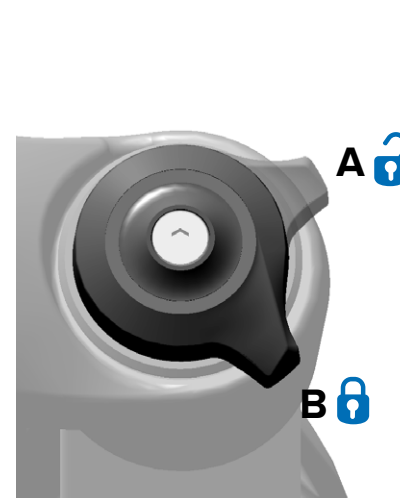

RL / TK

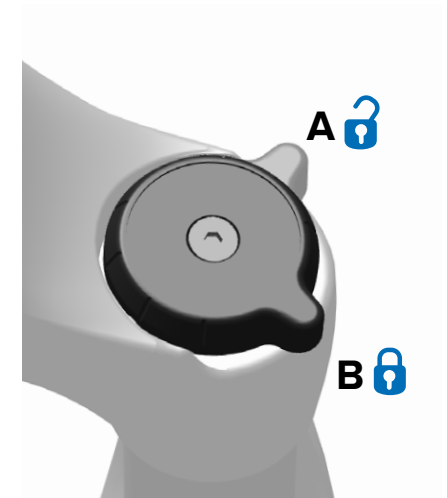

RL / TK - Paragon

Fork Lockout Compliance and Blow-Off

Lockout mode features key rider benefits when activated - **Compliance** and **Blow-Off**.

Motion Control and Turnkey:

(A) Compliance - A fixed amount of suspension fork movement that improves traction and control over small bumps while in the **Lock** position.

When locked out, a small amount of compliance prevents the wheel from bouncing off of impacts which helps maintain traction.

Charger Race Day Damper, Charger Damper, Charger 2 Damper, Charger 2.1 Damper, Motion Control, and Turnkey:

(B) Blow-Off - A valve in the compression damper that allows the suspension fork to safely compress if an impact greater than the valve's lockout force is encountered, such as a drop or large bump.

The Blow-Off valve allows the suspension fork to compress without causing internal damage to the damper.

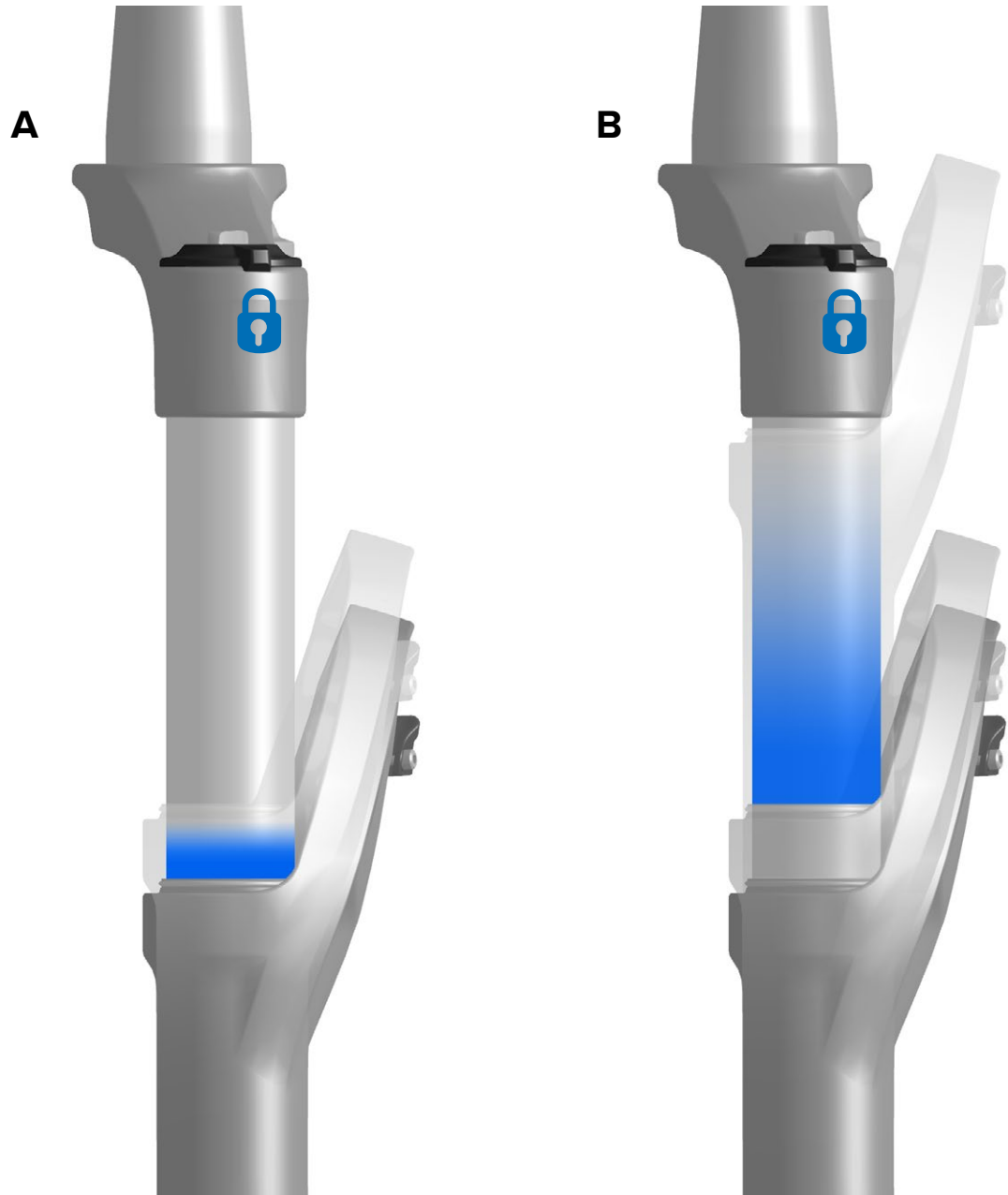

Rear Suspension Rebound Damping

Rebound damping controls rear shock extension/return speed which affects traction and control.

- **Optimal** rebound damping allows the shock to extend at a controlled speed, support the rider's weight through and after the bump, and maintain traction and control.
- Rebound that is **too fast** causes the shock to extend too quickly after the shock compresses which can cause the bicycle and rider to bounce or pitch forward. This can result in loss of control and stability.
- Rebound that is **too slow** prevents the shock from extending quickly enough to regain contact with the ground or prepare for the next impact. The shock remains in a more compressed state into the next bump which reduces available suspension travel and bump absorption.

Rebound damping can be tuned to rider weight, spring rate, and travel, as well as for terrain and rider preference.

As air pressure or spring rate increases, extension/return speed increases. To achieve the optimal setting, rebound damping may need to be increased when air pressure or spring rate increases.

After setting [sag](#), adjust the rebound damper, go for a ride, and adjust again as preferred.



To **decrease** rebound speed (slower return), turn the rebound adjuster **clockwise**.



To **increase** rebound speed (faster return), turn the rebound adjuster **counter-clockwise**.

Optimal

A The shock rebounds at a controlled speed. The rear wheel does not bounce off the bump or ground and maintains contact with the ground.

B The saddle rises slightly as the bump is absorbed, and drops slightly as the suspension compresses when the wheel contacts the ground after the bump. The shock rebounds in a controlled manner keeping the rider level with the ground as the next bump is absorbed. Suspension movement is predictable and controlled and the rider is not pitched upward or forward.

Adjustment:

No adjustment is needed.

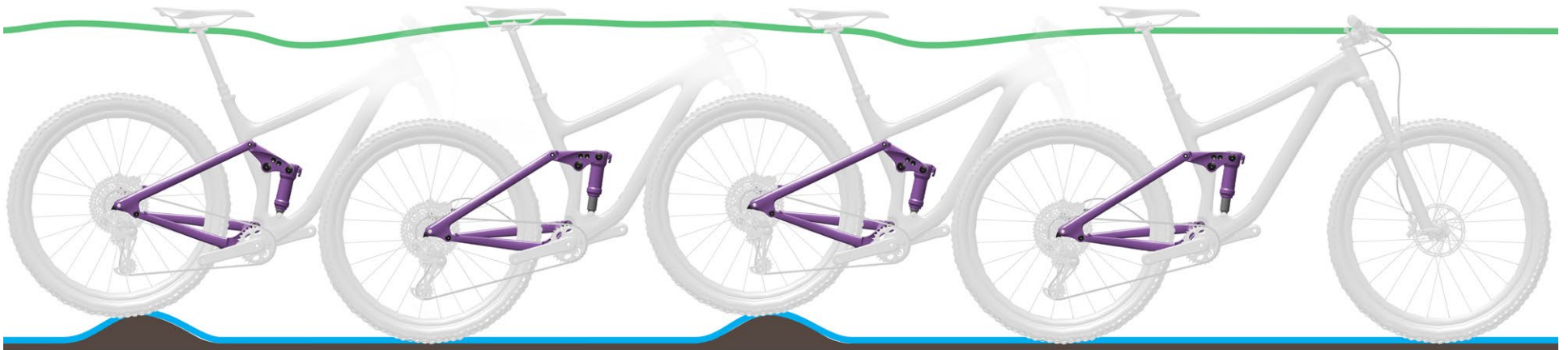

Too Fast

- A** The shock rebounds too quickly causing a 'pogo' or bounce effect after the wheel hits a bump and lands back on the ground. Traction and control are decreased due to the uncontrolled speed with which the shock extends after compression.
- B** The saddle and rider are forced upward after the wheel bounces off of a bump or the ground. Rider weight may shift upward and forward as the shock returns to full extension too quickly.

Adjustment:
Turn the rebound adjuster **clockwise** to **decrease** rebound speed, and **increase** traction and control.



Too Slow

A The shock does not extend quickly enough after absorbing a bump to reset for the next bump. The shock stays compressed through successive bumps, which reduces travel and contact with the ground, and increases firmness at the next impact. The rear wheel bounces off of the second bump because the shock does not extend quickly enough to regain contact with the ground and reset. Available travel and traction are decreased.

B The shock stays in a compressed state after contacting the first bump. When the rear wheel contacts the second bump the saddle follows the path of the rear wheel rather than remaining level with the ground. Available travel and bump absorption are reduced causing instability and control through successive bumps.

Adjustment:

Turn the rebound adjuster knob **counter-clockwise** to **increase** rebound speed and improve bump performance.



Rear Suspension Low Speed Compression Damping

Low speed compression (LSC) damping adjustment controls compression **stroke speed**, or the rate at which the shock compresses, during slow compression stroke scenarios. LSC affects bump absorption and efficiency during rider weight shifts, transitions, cornering, more gradual bump impacts, and braking.

Increased LSC damping:

- Keeps the shock riding higher in its travel. This may help the rider improve efficiency and maintain momentum over gradual, rolling terrain, through corners and while pedaling.
- Suspension compression may feel more firm on bumpy terrain.

Decreased LSC damping:

- Allows the shock to compress quickly and easily. This may help the rider maintain momentum and speed on bumpy terrain.
- Suspension compression may feel less firm on bumpy terrain.

LSC damping adjustments have less effect during high speed compression stroke scenarios. Drops and large bump impacts can exceed the compression damper's effective range of control and will cause the shock to compress suddenly and quickly, regardless of the LSC damper setting.

Increase LSC damping to reduce compression stroke speed and increase efficiency on rolling or smoother terrain, and while pedaling.



DELUXE
ULTIMATE



SUPER DELUXE
ULTIMATE



SUPER DELUXE
ULTIMATE DH



SUPER DELUXE COIL
ULTIMATE



SUPER DELUXE COIL
ULTIMATE DH

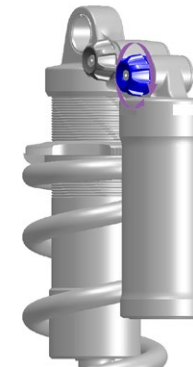

VIVID



VIVID AIR

To **increase** (+) Low Speed Compression damping (**firm**), turn the compression adjuster **clockwise**.

To **decrease** (-) Low Speed Compression damping (**soft**), turn the compression adjuster **counter-clockwise**.

Rolling Terrain

Low Speed Compression Damping - Open / Too Soft

The shock compresses low into the compression stroke through the low point of the terrain. Suspension travel is used quickly, the rider's weight may shift downward, and bicycle momentum may be reduced.

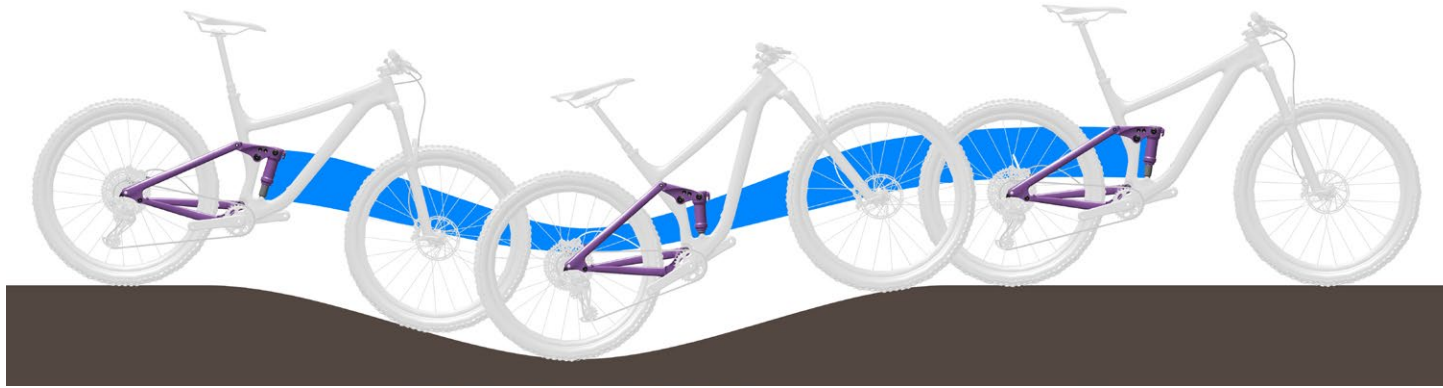

Low Speed Compression Damping - Mid to Firm

The shock resists compressing, remains higher in its travel, and helps the rider maintain speed into and through the rolling section of terrain.



Adjustment:

To improve efficiency on rolling and smoother terrain, rotate the compression adjuster **clockwise** to **increase** compression damping and firmness, and **decrease** compression stroke speed.

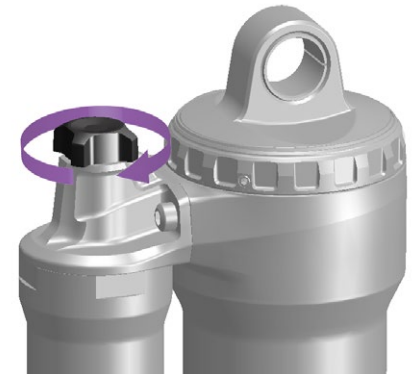

Bumps

Low Speed Compression Damping - Soft to Mid

- A** At bump impact, the shock compresses quickly and freely, and the bump is absorbed. Traction is maintained.
- B** The saddle rises slightly as the bump is absorbed.



Low Speed Compression Damping - Too Firm

- A** At bump impact, the shock compresses too slowly and the rear wheel deflects off of the bump. Traction is decreased.
- B** The saddle and rider are forced upward and forward, the rear wheel loses contact with the ground, and control is decreased.



Adjustment:

To **increase** small bump sensitivity, rotate the LSC or compression adjuster **counter-clockwise** to **decrease** compression damping and firmness, and **increase** compression stroke speed.

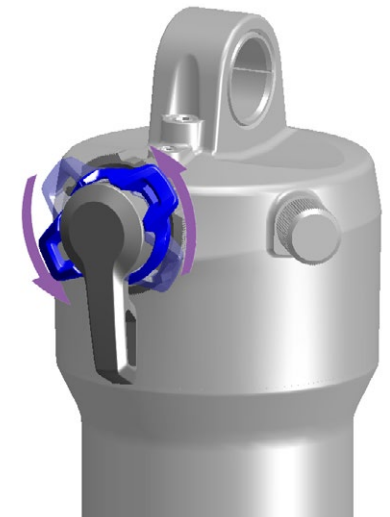
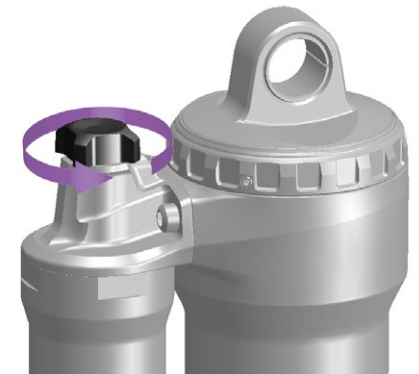

Rear Suspension Threshold

Threshold (T) mode prevents the rear shock from compressing until moderate to significant bump impact or downward force occurs. Threshold mode increases efficiency on smoother terrain.

Use the Threshold setting to increase pedaling efficiency on flat, rolling, smooth, or moderately bumpy terrain. When in Threshold mode, increased bicycle speed will increase bump impact force causing the shock to compress and absorb the bump.

- When the adjuster is in the (A) Open position the shock will compress quickly and freely through its full range of travel.
- When the adjuster is in the (B) Threshold position the shock will resist compressing until moderate bump impact or downward force occurs.
- When the adjuster is in the (C) Lock position the shock will resist compressing into its travel until significant bump impact or downward force occurs.

To activate Threshold, rotate the adjuster lever to the Threshold position.

Threshold on remote-equipped shocks can be actuated with the handlebar mounted remote at any time during use. Refer to the appropriate remote user manual at www.sram.com/en/rockshox/products/remotes for more information.

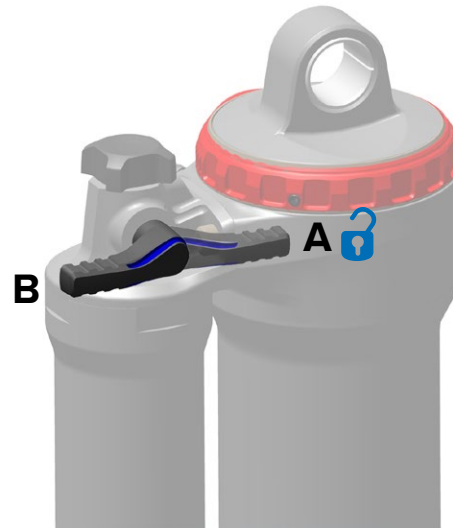

ULTIMATE RCT

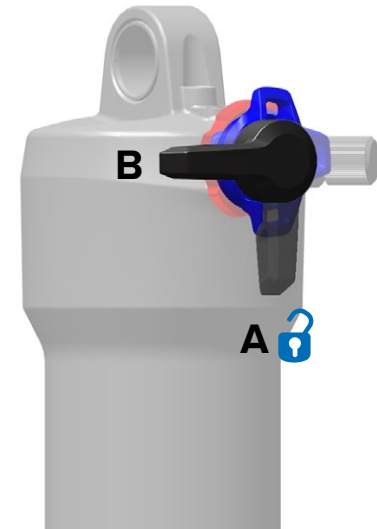

ULTIMATE RT

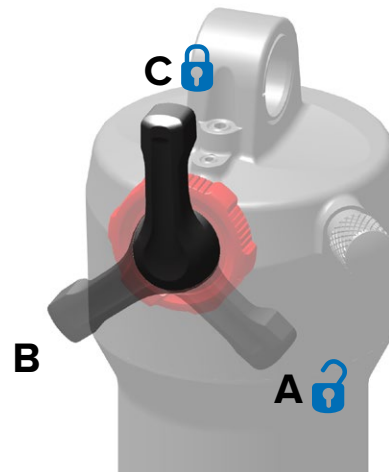

RT

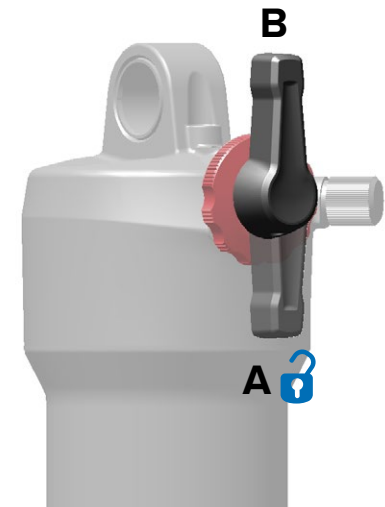

SELECT+ RT

Rear Suspension Lockout

Lockout (L) mode prevents the rear shock from compressing. Use lockout mode for maximum pedaling efficiency on smoother terrain.

- When the lockout adjuster lever is in the (A) Open position the shock is able to compress quickly and freely through its full range of travel.
- When the lockout adjuster lever is in the (B) Lock position the shock will resist compressing into its travel until significant bump impact or downward force occurs.

To activate lockout mode, rotate the adjuster lever to the Lock position.

To deactivate lockout mode, rotate the adjuster lever to the Open position.

Lockout on remote-equipped shocks can be actuated with the handlebar mounted remote at any time during use. Refer to the appropriate remote user manual at www.sram.com/en/rockshox/products/remotes for more information.



SIDLUXE ULTIMATE RL / SELECT+ RL

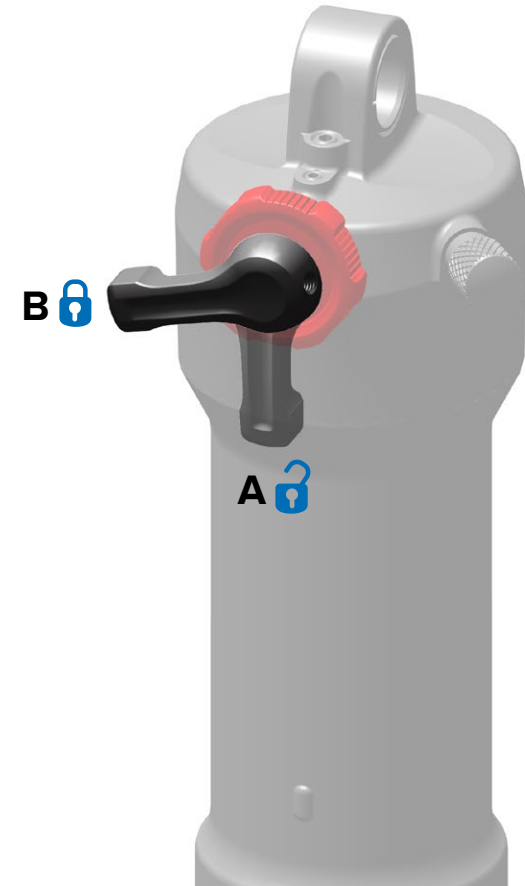

RL

Air Spring Bottom Out Tuning

Ending stroke air spring ramp, or bottom out resistance, can be tuned on select RockShox air spring forks compatible with air spring volume reducing Bottomless Tokens, as well as select RockShox air spring rear shocks compatible with air spring volume reducer Bottomless Tokens and Rings.

Bottomless Tokens and Rings reduce air spring volume and increase bottom out resistance. Reduced volume, with the correct sag set, increases mid to ending stroke spring ramp without significantly affecting sag and small to medium bump sensitivity. Increased spring ramp at bottom out can be beneficial on larger drops or fast bumpy trails where the fork uses most of its travel.

If sag is set correctly and the suspension bottoms out quickly and often, try adding compatible Bottomless Tokens, or Rings, until you find the preferred bottom out feel.

It is recommended that you repeat the [Sag](#) process and make damping adjustments after volume reducers have been installed or removed. Adding volume reducers may cause the suspension to rebound quicker. Rebound damping may need to be increased to compensate.

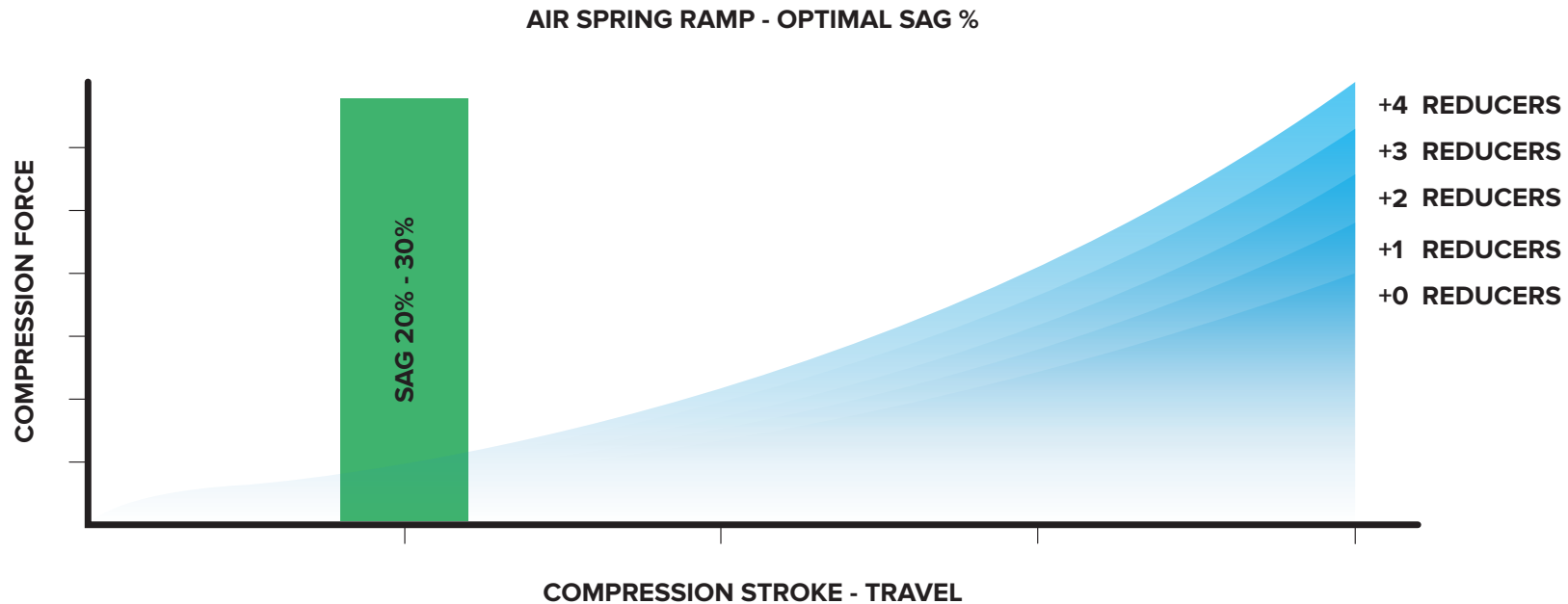

Bottomless Tokens and Rings

To avoid damaging the fork or rear shock, the maximum number of Bottomless Tokens or Rings installed should **not** be exceeded.

For suspension forks, refer to the appropriate model year *RockShox Front Suspension Oil, Air, Coil, Token, and Specification* document for the maximum number of Bottomless Tokens compatible with your fork.

For rear shocks, refer to the Rear Suspension User Manual for the maximum number of Bottomless Tokens and Rings.

For a complete list of available Bottomless Tokens and Rings consult the *RockShox Spare Parts Catalog*.

For volume reducer installation and removal procedures, consult the service manual for your fork or rear shock.

All related technical documents can be found at www.sram.com/service.



Dual Position Air - Bottomless Tokens



Solo Air and DebonAir - Bottomless Tokens



Monarch & Monarch Plus
Bottomless Rings

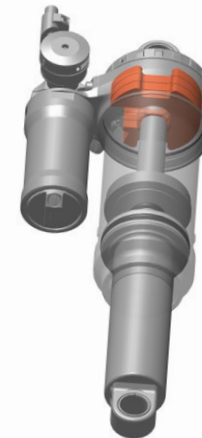

Deluxe & Super Deluxe
Bottomless Tokens



SIDLuxe
Bottomless Tokens

Fork Models and Damper Adjustments

Model	Damper	Damper Adjustments					
		Rebound	Low Speed Compression	High Speed Compression	Threshold	Lockout	Remote
Ultimate / RC2	Charger 2, Charger 2.1	✓	✓	✓	-	-	-
Ultimate / RCT3	Charger 2, Charger 2.1	✓	✓	-	✓	-	-
RCT R	Charger 2	✓	-	-	✓	-	✓
Ultimate / RLC	Charger 2	✓	✓	-	-	✓	-
Ultimate / RLC R	Charger 2	✓	✓	-	-	✓	✓
Select+ / RC	Charger 2, Charger 2.1	✓	✓	-	-	-	-
RC R	Charger 2	✓	-	-	-	-	✓
Select / RC	Charger RC	✓	✓	-	-	-	-
XX	Motion Control	✓	-	-	-	✓	✓
Ultimate / Select+ RL	Charger Race Day, Charger 2	✓	✓	-	-	✓	-
Select RL	Charger	✓	✓	-	-	✓	-
RL	Motion Control	✓	✓	-	-	✓	-
Ultimate / Select+ RL R	Charger Race Day, Charger 2	✓	✓	-	-	✓	✓
Select RL R	Charger	✓	✓	-	-	✓	-
RL R	Motion Control	✓	✓	-	-	✓	✓
RC	Motion Control	✓	✓	-	-	-	-
RC R	Motion Control	✓	✓	-	-	-	✓
TK R	TurnKey	✓	-	-	-	✓	✓
TK	TurnKey	-	-	-	-	✓	-
R	Charger R	✓	-	-	-	-	-
R	Rebound	✓	-	-	-	-	-

Rear Shock Models and Damper Adjustments

Model	Damper Adjustments					
	Low Speed Rebound	High Speed Rebound	Low Speed Compression	Threshold	Lockout	Remote
Ultimate / RT3	✓	-	-	✓	✓	-
Ultimate / RCT	✓	-	✓	✓	-	-
Ultimate Remote / RTR	✓	-	-	✓	-	✓
Ultimate DH / RC	✓	-	✓	-	-	-
Ultimate / RL	✓	-	-	-	✓	-
Ultimate / RLR	✓	-	-	-	✓	✓
XX	✓	-	-	-	✓	✓
Select+ / RC3	✓	-	✓	✓	✓	-
Select+ / RLR	✓	-	-	-	✓	✓
Select+ / RL	✓	-	-	-	✓	-
Select+ / RT	✓	-	-	✓	-	-
Select / R	✓	-	-	-	-	-
R2C	✓	✓	✓	-	-	-

These are registered trademarks of SRAM, LLC:

1:1[®], Accuwatt[®], Avid[®], AXS[®], Bar[®], Blackbox[®], BoXXer[®], DoubleTap[®], Elita[®], eTap[®], Firecrest[®], Firex[®], Grip Shift[®], GXP[®], Hammerschmidt[®], Holzfeller[®], Hussefelt[®], i-Motion[®], Judy[®], Know Your Powers[®], NSW[®], Omnium[®], Pike[®], PowerCal[®], PowerLock[®], PowerTap[®], Qollector[®], Quarq[®], RacerMate[®], Reba[®], RockShox[®], Ruktion[®], Service Course[®], ShockWiz[®], SID[®], Single Digit[®], Speed Dial[®], Speed Weaponry[®], Spinscan[®], SRAM[®], SRAM APEX[®], SRAM EAGLE[®], SRAM FORCE[®], SRAM RED[®], SRAM RIVAL[®], SRAM VIA[®], Stylo[®], Torpedo[®], Truvativ[®], TyreWiz[®], Varicrank[®], Velotron[®], X0[®], X01[®], X-SYNC[®], XX1[®], Zed tech[®], ZIPP[®]

These are registered logos of SRAM, LLC:



These are trademarks of SRAM, LLC:

10K[™], 1X[™], 202[™], 30[™], 35[™], 302[™], 303[™], 404[™], 454[™], 808[™], 858[™], 3ZERO MOTO[™], ABLC[™], AeroGlide[™], AeroBalance[™], AeroLink[™], Airea[™], Air Guides[™], AKA[™], AL-7050-TV[™], Automatic Drive[™], Automatix[™], AxCad[™], Axial Clutch[™], BB5[™], BB7[™], BB30[™], Bleeding Edge[™], Blipbox[™], BlipClamp[™], BlipGrip[™], Blips[™], Bluto[™], Bottomless Tokens[™], Cage Lock[™], Carbon Bridge[™], Centera[™], Charger 2[™], Charger[™], Clickbox Technology[™], Clics[™], Code[™], Cognition[™], Connectamajig[™], Counter Measure[™], DD3[™], DD3 Pulse[™], DebonAir[™], Deluxe[™], Deluxe Re:Aktiv[™], Descendant[™], DFour[™], DFour91[™], Dig Valve[™], DirectLink[™], Direct Route[™], DOT 5.1[™], Double Decker[™], Double Time[™], Dual Flow Adjust[™], Dual Position Air[™], DUB[™], DZero[™], E300[™], E400[™], Eagle[™], E-Connect4[™], E-matic[™], ErgoBlade[™], ErgoDynamics[™], ESP[™], EX1[™], Exact Actuation[™], Exogram[™], Flow Link[™], FR-5[™], Full Pin[™], Gnar Dog[™], Guide[™], GX[™], Hard Chrome[™], Hexfin[™], HollowPin[™], Howitzer[™], HRD[™], Hybrid Drive[™], Hyperfoil[™], i-3[™], Impress[™], Jaws[™], Jet[™], Kage[™], Komfy[™], Level[™], Lyrik[™], MatchMaker[™], Maxle[™], Maxle 360[™], Maxle DH[™], Maxle Lite[™], Maxle Lite DH[™], Maxle Stealth[™], Maxle Ultimate[™], Micro Gear System[™], Mini Block[™], Mini Cluster[™], Monarch[™], Monarch Plus[™], Motion Control[™], Motion Control DNA[™], MRX[™], Noir[™], NX[™], OCT[™], OmniCal[™], OneLoc[™], Paragon[™], PC-1031[™], PC-1110[™], PC-1170[™], PG-1130[™], PG-1050[™], PG-1170[™], Piggyback[™], Poploc[™], Power Balance[™], Power Bulge[™], PowerChain[™], PowerDomeX[™], Powered by SRAM[™], PowerGlide[™], PowerLink[™], Power Pack[™], Power Spline[™], Predictive Steering[™], Pressfit[™], Pressfit 30[™], Prime[™], Qalvin[™], R2C[™], RAIL[™], Rapid Recovery[™], Re:Aktiv ThruShaft[™], Recon[™], Reverb[™], Revelation[™], Riken[™], Rise[™], ROAM[™], Roller Bearing Clutch[™], RS-1[™], Sag Gradients[™], Sawtooth[™], SCT - Smart Coasterbrake Technology, Seeker[™], Sektor[™], SHIFT[™], ShiftGuide[™], Shorty[™], Showstopper[™], Side Swap[™], Signal Gear Technology[™], SL[™], SL-70[™], SL-70 Aero[™], SL-70 Ergo[™], SL-80[™], SI-88[™], SLC2[™], SL SPEED[™], SL Sprint[™], Smart Connect[™], Solo Air[™], Solo Spoke[™], SpeedBall[™], Speed Metal[™], SRAM APEX 1[™], SRAM Force 1[™], SRAM RIVAL 1[™], S-series[™], Stealth-a-majig[™], StealthRing[™], Super-9[™], Supercork[™], Super Deluxe[™], Super Deluxe Coil[™], SwingLink[™], TaperCore[™], Timing Port Closure[™], Tool-free Reach Adjust[™], Top Loading Pads[™], Torque Caps[™], TRX[™], Turnkey[™], TwistLoc[™], VCLC[™], Vivid[™], Vivid Air[™], Vuka Aero[™], Vuka Alumina[™], Vuka Bull[™], Vuka Clip[™], Vuka Fit[™], Wide Angle[™], WiFLi[™], X1[™], X5[™], X7[™], X9[™], X-Actuation[™], XC[™], X-Dome[™], XD[™], XD Driver Body[™], XDR[™], XG-1150[™], XG-1175[™], XG-1180[™], XG-1190[™], X-Glide[™], X-GlideR[™], X-Horizon[™], XLoc Sprint[™], XX[™], Yari[™], Zero Loss[™]



Specifications and colors subject to change without prior notice.

© 2020 SRAM, LLC

ASIAN HEADQUARTERS

SRAM Taiwan
No. 1598-8 Chung Shan Road
Shen Kang Hsiang, Taichung City
Taiwan R.O.C.

WORLD HEADQUARTERS

SRAM LLC
1000 W. Fulton Market, 4th Floor
Chicago, Illinois 60607
United States

EUROPEAN HEADQUARTERS

SRAM Europe
Paasbosweg 14-16
3862ZS Nijkerk
The Netherlands