

SWISS PREMIUM E-BIKES

**FLYER**



## FLYER UPSTREET 2

DE Faltanleitung

FR Procédure de pliage

IT Istruzioni pieghevoli

EN Bike folding instructions

NL Vouwinstructie

---

DE  
FR  
IT  
EN  
NL

# Das FLYER E-Bike und seine Bauteile

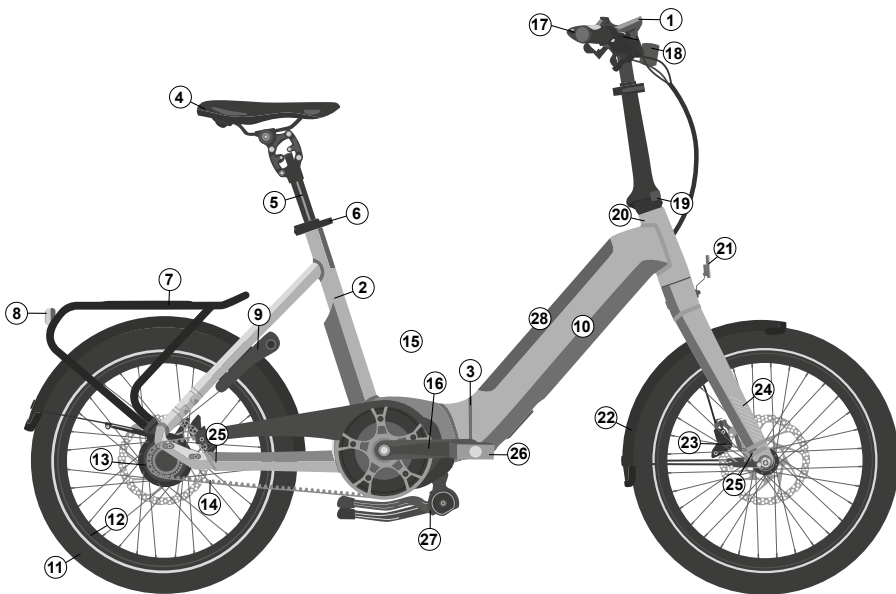

- |                                  |                                   |
|----------------------------------|-----------------------------------|
| ① Display                        | ⑮ Motor (unter Kettenschutz)      |
| ② Rahmen                         | ⑯ Kurbel                          |
| ③ faltgelenk mit sicherungshebel | ⑰ Lenker                          |
| ④ Sattel                         | ⑱ Scheinwerfer                    |
| ⑤ Sattelstütze                   | ⑲ faltbarer Vorbau                |
| ⑥ Sattelstützen-Schnellspanner   | ⑳ Steuersatz                      |
| ⑦ Gepäckträger                   | ㉑ Reflektor                       |
| ⑧ Rücklicht                      | ㉒ Schutzblech                     |
| ⑨ Rahmenschloss                  | ㉓ Bremse                          |
| ⑩ Akku                           | ㉔ Gabel                           |
| ⑪ Laufrad                        | ㉕ Fixierung im gefalteten Zustand |
| ⑫ Felge                          | ㉖ Faltpedale                      |
| ⑬ Nabe                           | ㉗ Ständer                         |
| ⑭ Kette/Riemen                   | ㉘ Bidonhalter                     |

# 1. Faltanleitung FLYER Upstreet2

Diese Faltanleitung enthält wichtige Informationen die Sie benötigen, um mit dem Faltvorgang Ihres neuen FLYERs vertraut zu werden, sich den Sicherheitsaspekten zu widmen und Schäden an Personen, Sachen und der Umwelt zu vermeiden. Bewahren Sie sie gut auf, halten Sie die Anleitung griffbereit und beachten Sie die Hinweise. Geben Sie diese Anleitung mit weiter, wenn Sie Ihren FLYER anderen Personen zur Verfügung stellen.

**i** Achten Sie immer darauf, dass Ihr FLYER Upstreet2 sicher steht, wenn Sie es in gefaltetem Zustand transportieren. Besonders bei Transporten in öffentlichen Verkehrsmitteln und im Auto achten Sie darauf, dass es nicht umfallen kann, wenn sich das Fahrzeug bewegt. Sichern Sie es evtl. zusätzlich oder halten Sie es fest. Bei einem Umfallen könnten sonst wichtige Bauteile beschädigt werden.

**i** Allfällige Wartungen, Servicearbeiten etc. dürfen nur durchgeführt werden, wenn das System ausgeschaltet ist.

## 1.1 Schnellspanner bedienen

Schnellspanner sind Vorrichtungen, die anstelle einer Schraubverbindung Bauteile am Fahrrad fixieren. Die Bedienung findet über zwei Elemente statt: Mit dem Schnellspannhebel bringen Sie die notwendige Klemmkraft auf, mit der Einstellmutter regulieren Sie, wie stark geklemmt wird. Diese Einstellung nehmen Sie vor, wenn der Schnellspannhebel geöffnet ist.

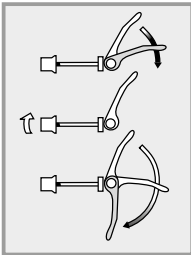

Einstellmutter lockern

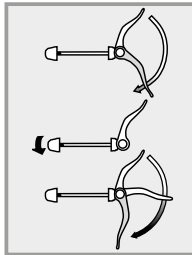

Einstellmutter anziehen



Der Schnellspanner und Verschlusshebel schliessen mit der korrekten Klemmkraft, wenn ab der Mitte des gesamten Hebelwegs Gegendruck zu spüren ist und am Ende des Hebelwegs die Kraft des Handballens notwendig ist, um den Hebel ganz zu schliessen.



- Alle Schnellspanner müssen fest geschlossen sein, bevor Sie losfahren.
- Überprüfen Sie alle Schnellspanner auch dann auf korrekten Sitz, wenn das Fahrzeug für kurze Zeit unbeaufsichtigt abgestellt war sowie vor jeder Fahrt.
- In geschlossenem Zustand muss der Schnellspannhebel dicht an Rahmen, Gabel oder Sattelstütze anliegen!



Zusätzlich zum Abschliessen des Faltrads sollten auch mit Schnellspanner befestigte Teile separat, z.B. mit einem Kabelschloss, angeschlossen werden. Damit können Sie einen Diebstahl der Teile erschweren.

## 1.2 Ein- und Nachstellen des Faltgelenks am Rahmen



Lassen Sie die Klemmkraft des Faltgelenks nach 500 Faltungen, oder wenn die Klemmkraft nachlässt, durch einen FLYER Fachhändler prüfen.



Korrekte Klemmkraft des Faltgelenks: 10 kg/98,1N

## 1.3 Faltanleitung des FLYER Upstreet2



Das Antriebssystem muss immer ausgeschaltet werden, bevor mit dem Klappvorgang begonnen wird.

Um das Zusammenfallen Ihres FLYER Upstreet2 einfach und sicher zu gestalten, ist er an allen wichtigen Stellen mit Schnellverschlüssen versehen.



Entfernen Sie vor dem Faltvorgang die Schlüssel aus Akku- und Fahrradschloss.



Klappen Sie den Mittelständer Ihres FLYER Upstreet2 auf, damit es im gefalteten Zustand nicht auf den Motor fallen kann.



Bringen Sie die Kurbeln vor dem Faltvorgang in eine waagerechte Position oder positionieren Sie das Pedal auf der linken Seite ganz nach unten.

1. Falten Sie zuerst die Pedale Ihres FLYER Upstreet2. Drücken Sie dazu seitlich auf die Pedale in Richtung der Kurbel (1) und klappen Sie sie um 90° um (2).

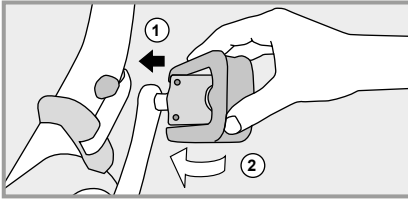

2. Stellen Sie sich auf die linke Seite des Fahrrads. Öffnen Sie den Sattelschnellspanner (1) und fahren die Sattelstütze bis ganz nach unten ein (2).

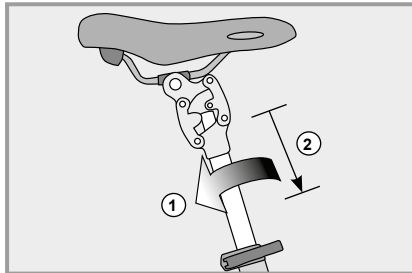

Schliessen Sie den Schnellspanner wieder (3), damit der Sattel in seiner Position bleibt.

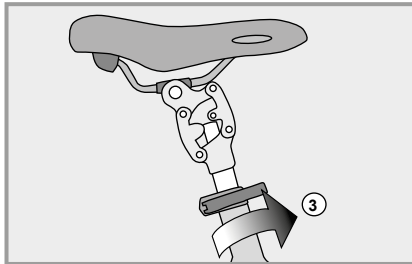

3. Entarretieren Sie den Sicherungshebel (1) des faltbaren Vorbaus, indem Sie auf den runden Entarretierungsknopf drücken.

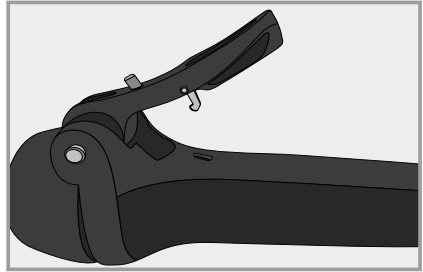

Klappen Sie den Vorbau mitsamt dem Lenker nach unten

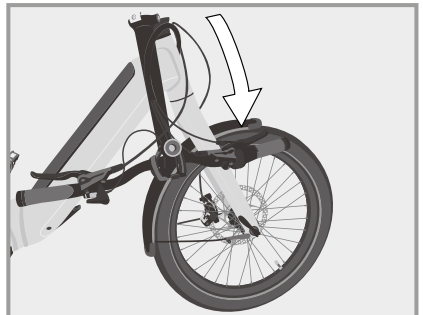
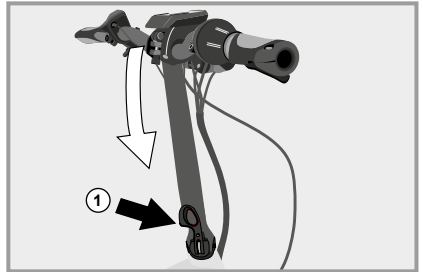

4. Entriegeln Sie den Verschlusshebel (2) indem Sie die Sicherungsfeder (3) nach oben drücken.

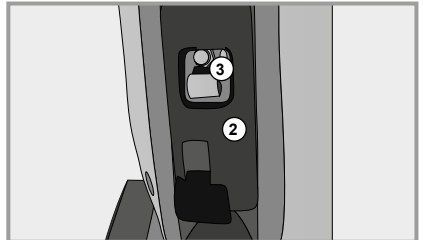

5. Drücken Sie den Verschlusshebel (2) ganz nach unten, bis der Falverschluss entriegelt wird.



Dann können Sie den vorderen Teil des Rahmens nach links falten (2).

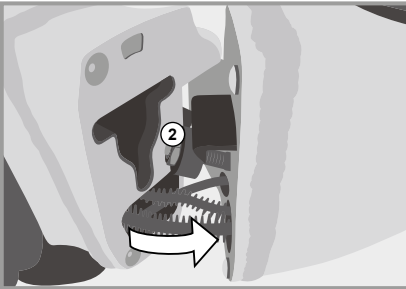

6. Bewegen Sie den vorderen und hinteren Teil des Rahmens so weit aufeinander zu, bis die Klickfix-Faltsicherung am Vorderrad (1) und Hinterrad (2) einrasten kann.

Klickfix-Schnappverschluss an der Starrgabel (1)  
Klickfix-Rastzapfen am Hinterbau (2)



Prüfen Sie ob die Sicherung zwischen Vorderradgabel und linken Kettenstrebe vollständig eingerastet ist. Ansonsten kann sich das Faltrad beim Anheben öffnen was Verletzungen zur Folge haben kann.

7. So sollte Ihr FLYER im korrekt gefalteten Zustand aussehen:

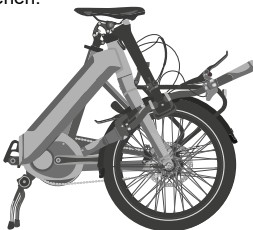

Klappen Sie vor dem Transport den Mittelständer wieder ein.

### 1.4 FLYER Upstreet2 aufklappen

Bevor Sie mit dem Aufklappen Ihres FLYER Upstreet2 beginnen, klappen Sie den Mittelständer herunter und bringen Sie die Kurbeln entweder in waagerechter Position oder positionieren Sie die linke Kurbel ganz nach unten.

1. Lösen Sie die Klickfix-Faltsicherung, indem Sie den roten Auslösemechanismus betätigen.

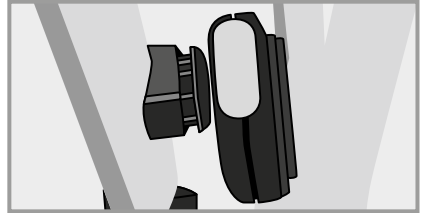

2. Drücken Sie den Verschlusshebel des Rahmengelenks nach unten und bewegen Sie den vorderen und den hinteren Teil des Rahmens voneinander weg, bis sie eine gerade Linie bilden und sich nicht weiter bewegen lassen.

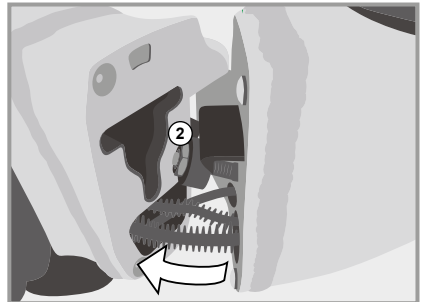

3. Das Rahmengelenk schliesst, indem der Verschlusshebel (2) nach oben eingerastet wird.

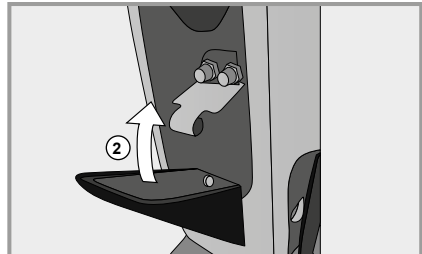



Versichern Sie sich mit einem Kontrollgriff, dass das Rahmengelenk eingerastet ist.



Achten Sie auf ausreichende Klemmkraft. Bei mangelnder Klemmkraft wenden Sie sich umgehend an Ihren FLYER Fachhändler zum Nachstellen des Verschlusshebels. Prüfen Sie den sicheren Sitz des Hebels.

Falten Sie dann den Vorbau wieder nach oben und arretieren Sie diesen mit dem Schnellspanner.

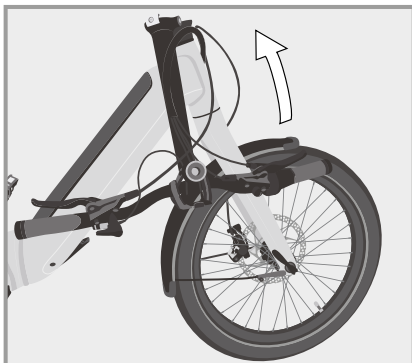

3. Öffnen Sie den Sattelstützen-Schnellspanner (1)

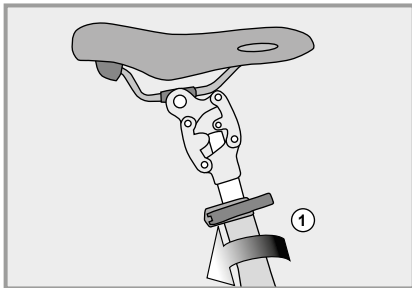

und ziehen Sie die Sattelstütze bis zur gewünschten Höhe aus dem Sattelrohr (2). Schliessen Sie dann den Schnellspanner wieder korrekt (3), damit der Sattel sicher in seiner Position bleibt.

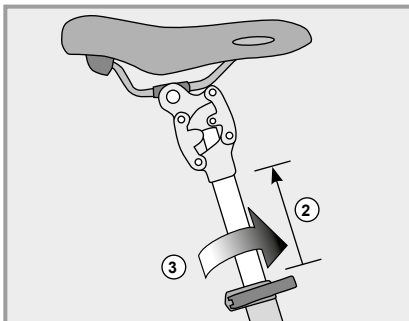

Auf der Sattelstütze ist markiert, bis wohin sie maximal aus dem Rahmen gezogen werden darf. Ziehen Sie die Sattelstütze nie weiter als bis zu dieser Markierung aus!

4. Entfalten Sie nun die Pedale Ihres FLYER Upstreet2. Klappen Sie sie um 90 ° nach aussen (1). Ziehen Sie sie leicht nach aussen (2), damit sie in der Fahrposition einrasten.

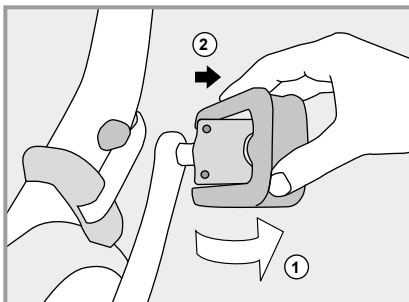

Überprüfen Sie alle Schnellspanner und Verschlüsse auf korrekte und sichere Schliessung.



Klappen Sie vor Beginn der Fahrt den Mittelständer wieder ein!



Stellen Sie vor jeder Fahrt sicher, dass die Klemmkraft des Faltegelenks gemäss Angaben in Kapitel 1.2 ausreichend ist und stellen Sie sicher, dass alle Sicherungen korrekt geschlossen sind. Während der Fahrt muss das Faltegelenk immer gesichert sein und darf nicht manipuliert werden.



Lassen Sie den Falverschluss regelmässig von Ihrem FLYER Fachhändler überprüfen. Drehen Sie nicht selber an den Verschlusschrauben.

SWISS PREMIUM E-BIKES

**FLYER**



## FLYER UPSTREET 2

FR Procédure de pliage

---

FR

# Les constituants du FLYER e-bike

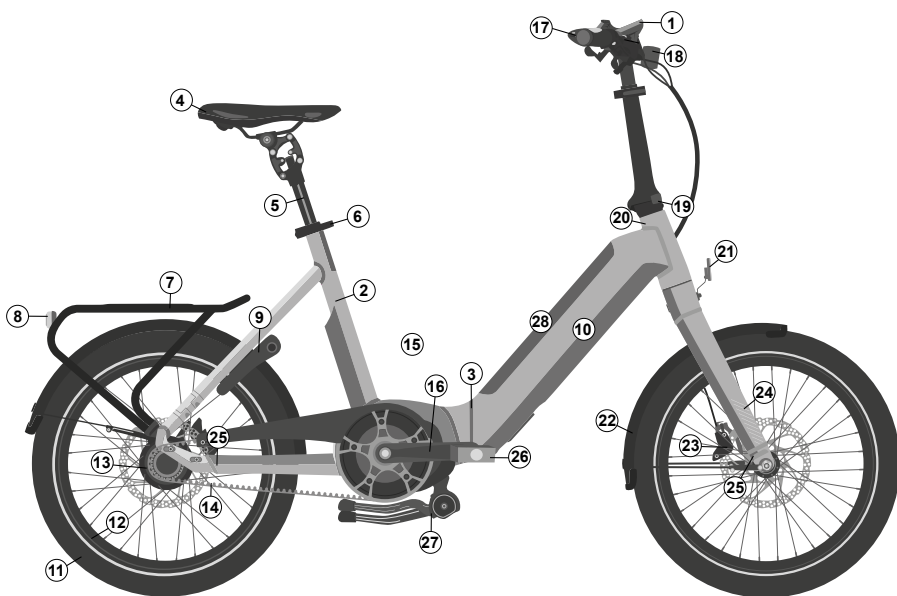

- |  |  |
|--|--|
| ① Afficheur                                | ⑮ Moteur (caché par le carter de chaîne) |
| ② Cadre                                    | ⑯ Manivelle                              |
| ③ Articulation avec levier de verrouillage | ⑰ Guidon                                 |
| ④ Selle                                    | ⑱ Feu avant                              |
| ⑤ Tige de selle                            | ⑲ Potence pliable                        |
| ⑥ Blocage rapide de la tige de selle       | ⑳ Jeu de direction                       |
| ⑦ Porte-bagages                            | ㉑ Réflecteur                             |
| ⑧ Feu arrière                              | ㉒ Garde-boue                             |
| ⑨ Serrure de cadre                         | ㉓ Freins                                 |
| ⑩ Batterie                                 | ㉔ Fourche                                |
| ⑪ Roue                                     | ㉕ Partie du mécanisme de repliage        |
| ⑫ Jante                                    | ㉖ Pédales repliables                     |
| ⑬ Moyeu                                    | ㉗ Béquille                               |
| ⑭ Chaîne/Courroie                          | ㉘ Fixation gourde                        |

# 1. Procédure de pliage FLYER Upstreet2

Vous trouverez dans la présente notice toutes les explications nécessaires pour apprendre à maîtriser la procédure de pliage de votre nouveau FLYER, y compris du point de vue de la sécurité, de façon à prévenir les dommages matériels, corporels et environnementaux. Conservez-la soigneusement en un endroit aisément accessible et respectez bien ses instructions. Veuillez remettre la présente notice à toute autre personne qui pourrait utiliser votre FLYER.

**i** Il faut veiller à ce qu'une fois plié votre FLYER Upstreet2 soit toujours bien maintenu en position verticale. En particulier lorsque vous le transportez en voiture ou dans les transports publics, il faut s'assurer de ce qu'il ne puisse pas tomber en cours de déplacement. Il faut le tenir, ou éventuellement l'arrimer. S'il tombait, cela pourrait endommager des pièces importantes.

**i** Il faut que l'assistance électrique soit coupée avant de procéder à toute intervention sur le vélo.

## 1.1 Utilisation des blocages rapides

Un blocage rapide est un dispositif permettant de fixer des éléments à la bicyclette sans vissage ou boulonnage. Un blocage rapide a deux fonctionnalités : le levier permet d'assurer le blocage avec la force nécessaire, l'écrou permet de régler la force de blocage. Ce réglage se fait en position ouverte.

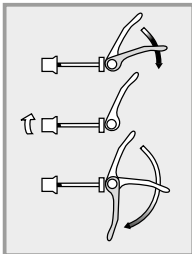

Desserrer l'écrou de réglage

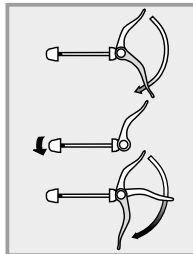

Pour un blocage plus fort

**i** Pour un bon blocage d'un blocage rapide du verrou de l'articulation, il faut qu'à partir du milieu de la course du levier on commence à sentir une résistance, puis qu'on soit obligé d'appuyer avec la paume de la main pour rabattre le levier complètement.



- Tous les blocages rapides doivent être bien bloqués avant utilisation.
- Vérifiez le bon positionnement de tous les blocages rapides lorsque le vélo est resté un moment sans surveillance, et avant chaque départ.
- En position fermée, le levier de blocage doit être bien rabattu à proximité du cadre, de la fourche ou de la tige de selle.



Une fois le vélo replié, on a intérêt à protéger par un câble antivol les pièces fixées au vélo par un blocage rapide. Cela en rend le vol plus difficile.

## 1.2 Réglage de l'articulation du cadre



Il faut faire contrôler le blocage de l'articulation par un spécialiste FLYER après 500 pliages, ou bien si on remarque qu'il se bloque moins bien.



La valeur de blocage de l'articulation est de 10kg/98,1N

## 1.3 Procédure de pliage du FLYER Upstreet2



Avant de commencer à plier le vélo, coupez l'assistance électrique.

Afin de rendre le pliage de votre FLYER Upstreet2 simple et sûr, des serrages rapides ont été mis en place à tous les endroits importants.



Avant de commencer, retirez les clés de la serrure de la batterie et de l'antivol.



Baisser la béquille de votre FLYER Upstreet2 pour qu'elle ne vienne pas buter sur le moteur une fois le vélo replié.



Avant le pliage, amener les manivelles en position horizontale, ou bien abaisser au maximum la pédale gauche.

1. On commence par replier les pédales. Pour ce faire, appuyez latéralement sur les pédales en direction de la manivelle (1) et rabattez-les à 90° (2).

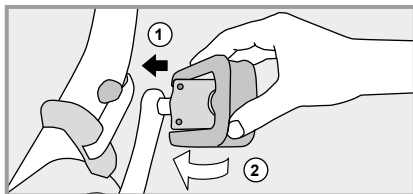

2. Mettez-vous du côté gauche du vélo. Ouvrez le serrage rapide de la selle (1) et rentrez entièrement la tige de selle en la faisant glisser vers le bas (2).

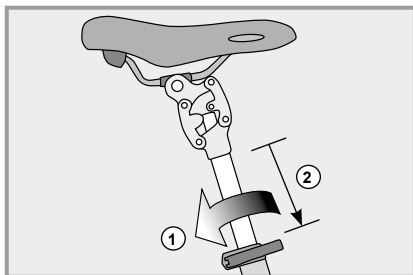

Refermez le serrage rapide (3) afin que la selle demeure dans cette position.

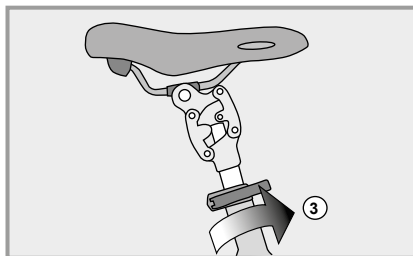

3. Débloquez le levier de verrouillage (1) de la potence pliable en appuyant sur le bouton rond de déblocage.

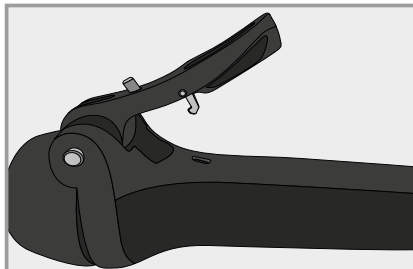

Rabattez la potence avec le guidon vers le bas.

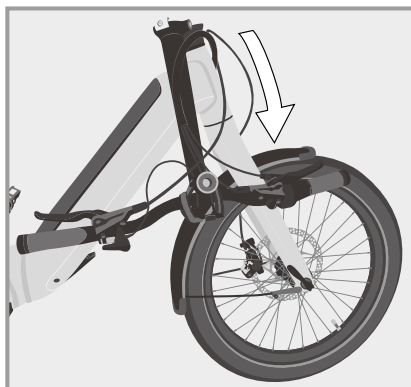
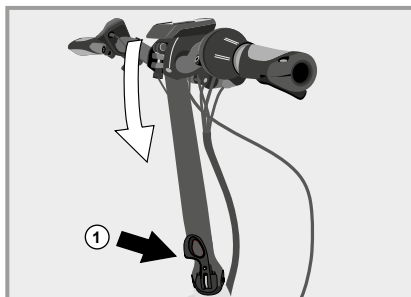

4. Déverrouillez le levier de blocage (2) en appuyant sur le ressort d'arrêt (3) vers le haut.

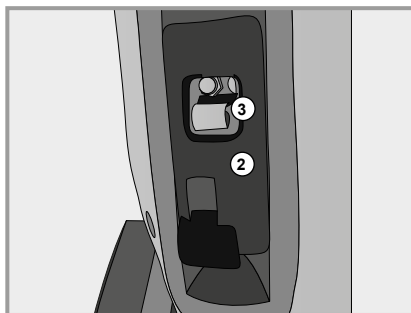

5. Enfoncez le levier de blocage (2) tout en bas jusqu'à déverrouiller l'articulation de pliage.

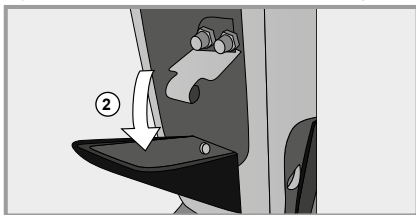

Cela fait, la partie avant du cadre peut se replier vers la gauche (2).

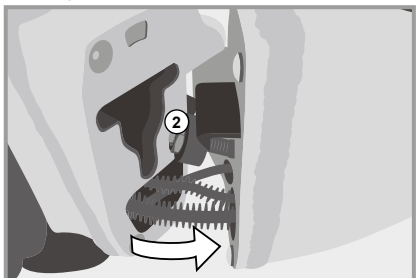

6. Rabattez l'une sur l'autre la partie avant du cadre et la partie arrière jusqu'au verrouillage du dispositif de sécurité Klickfix sur la roue avant (1) et arrière (2).

Loquet Klickfix sur la fourche rigide (1)  
Tourillon d'arrêt Klickfix sur le triangle arrière (2)



-  Vérifiez le bon enclenchement du verrouillage entre la fourche et la base gauche, faute de quoi le vélo pourrait s'ouvrir au moment où on le soulève, ce qui peut provoquer des blessures.

7. Correctement plié, votre FLYER devrait se présenter de la manière suivante:

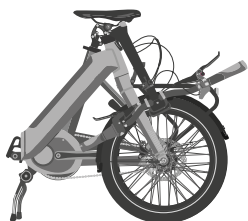

-  Avant le transport, rabattre la béquille centrale.

## 1.4 Dépliage du FLYER Upstreet2

Avant de commencer à déplier votre FLYER Upstreet2, abaisser la béquille et amener les manivelles en position horizontale, ou bien positionner la manivelle gauche vers le bas.

1. Déverrouiller le dispositif de sécurité Klickfix en actionnant le mécanisme de dégagement rouge.

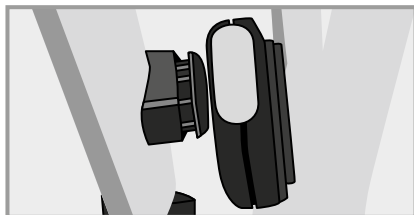

2. Appuyer vers le bas sur le levier de blocage sur l'articulation du cadre et déplier au maximum les deux moitiés du cadre jusqu'à ce qu'elles retrouvent leur alignement et ne bougent plus.

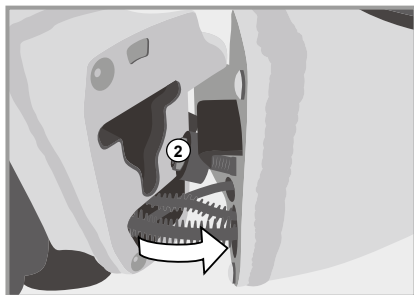

3. L'articulation du cadre est fermée dès lors que le levier de blocage (2) est verrouillé en haut.

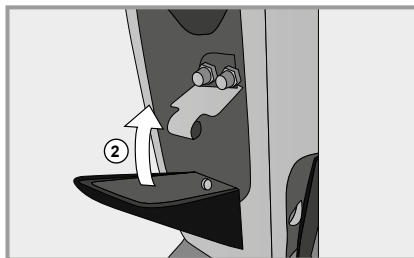



Vérifier que l'articulation du cadre est bien verrouillée.



Vérifier que la force de blocage est suffisante. Si ce n'est pas le cas, cela veut dire que le mécanisme a besoin d'un réglage, qu'il faut confier sans tarder à votre spécialiste FLYER. Vérifier le bon positionnement du levier.

Déplier la potence vers le haut et l'immobiliser à l'aide du blocage rapide.

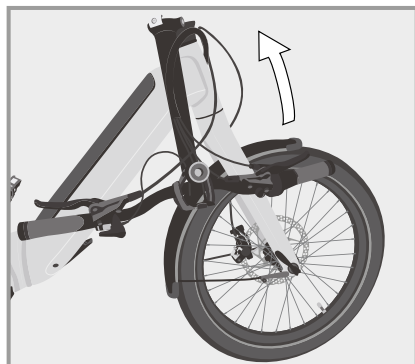

3. Ouvrir le blocage rapide de la tige de selle (1)

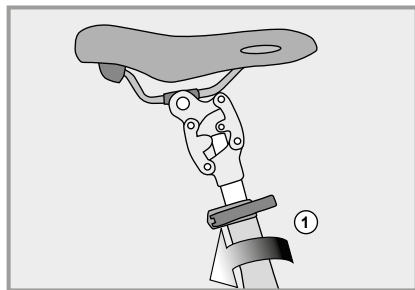

et monter la selle jusqu'à la hauteur voulue (2). Cela fait, bien refermer le blocage rapide (3), pour que la selle soit bien fixée.

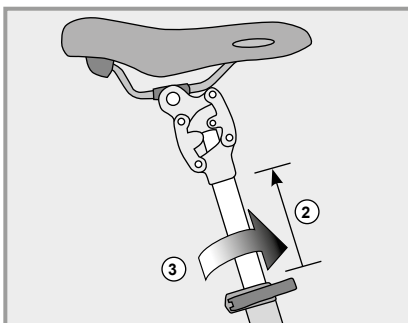

La tige de selle porte une marque qui indique jusqu'à quelle hauteur maximale elle peut sortir du cadre. Ne tirez jamais la tige de selle au-delà de cette marque!

4. Déployez les pédales de votre FLYER Upstreet2. Dépliez-les de 90° vers l'extérieur (1). Tirez légèrement vers l'extérieur (2), de façon à ce qu'elles se verrouillent en position de conduite.

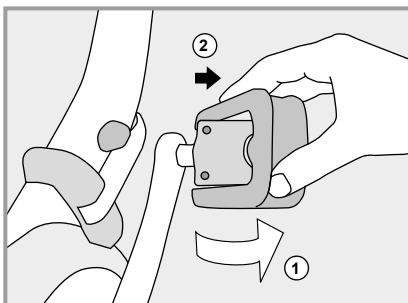

Contrôler la bonne position et le bon serrage de tous les blocages rapides et tous les verrouillages.



Avant de repartir, penser à rabattre la béquille!



Chaque fois que vous allez utiliser votre vélo, vérifiez que la force de blocage de l'articulation du vélo soit suffisante, ainsi qu'expliqué à la section 1.2, et vérifiez tous les verrouillages. En cours de route l'articulation doit toujours rester verrouillée. Il faut s'abstenir de la manipuler.



Faites contrôler l'articulation régulièrement par votre spécialiste FLYER. Ne tournez jamais vous-même les vis de verrouillage.

SWISS PREMIUM E-BIKES

**FLYER**



## FLYER UPSTREET 2

IT Istruzioni pieghevoli

---

IT

# La FLYER e-bike e i suoi componenti

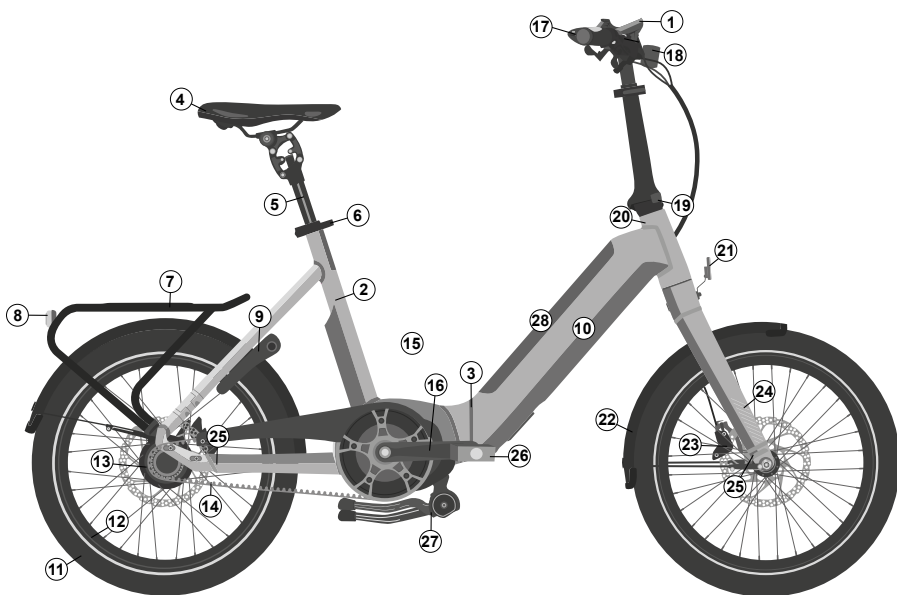

- |   |   |
|---|---|
| ① Display                                 | ⑮ Motore (sotto alla protezione della catena) |
| ② Telaio                                  | ⑯ Pedivelle                                   |
| ③ Giunto pieghevole con leva di sicurezza | ⑰ Manubrio                                    |
| ④ Sella                                   | ⑱ Proiettore                                  |
| ⑤ Reggisella                              | ⑲ Avancorpo pieghevole                        |
| ⑥ Sgancio rapido del reggisella           | ⑳ serie sterzo                                |
| ⑦ Portapacchi                             | ㉑ Riflettore                                  |
| ⑧ Faro posteriore                         | ㉒ Parafango                                   |
| ⑨ Lucchetto per il telaio                 | ㉓ Freno                                       |
| ⑩ Batteria                                | ㉔ Forcella                                    |
| ⑪ Ruota portante                          | ㉕ Fissaggio in modalità piegata               |
| ⑫ Cerchio                                 | ㉖ Pedali pieghevoli                           |
| ⑬ Mozzo                                   | ㉗ Cavalletto                                  |
| ⑭ Catena/cinghia                          | ㉘ Portaborraccia                              |

# 1. Istruzioni per piegare FLYER Upstreet2

Queste istruzioni contengono importanti informazioni, necessarie per prendere dimestichezza con il processo di piegamento della nuova FLYER, dedicarsi agli aspetti relativi alla sicurezza ed evitare danni a persone, cose e all'ambiente. Conservarle con cura, tenerle a portata di mano e osservare le avvertenze. Se la FLYER viene messa a disposizione di terzi, consegnare anche queste istruzioni.

**i** Accertarsi che la FLYER Upstreet2 sia al sicuro quando trasportata da piegata. In particolare per il trasporto su mezzi pubblici e in auto, assicurarsi che non si rovesci quando il veicolo è in movimento. Se necessario, fissarla ulteriormente oppure tenerla saldamente. In caso di rovesciamento, i componenti essenziali potrebbero subire dei danni.

**i** Eseguire eventuali lavori di manutenzione, assistenza, ecc. solo quando il sistema è spento.

## 1.1 Comando degli sganci rapidi

Gli sganci rapidi sono dispositivi che sostituiscono i collegamenti a vite nel fissaggio dei componenti alla bicicletta. Il comando avviene tramite due elementi: con la leva di sgancio rapido si applica la forza di serraggio necessaria; con la regolazione si stabilisce la forza del blocco. La regolazione viene effettuata quando la leva di sgancio rapido è aperta.

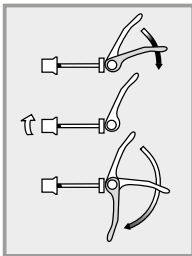

Serraggio del dado di regolazione

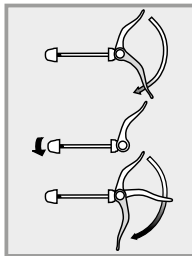

Serrare il dado di regolazione

**i** Lo sgancio rapido e la leva di bloccaggio si chiudono con la forza di bloccaggio corretta quando dal centro dell'intera corsa della leva si avverte una contropressione e al termine della corsa sia necessaria la forza dell'eminenza tenar per chiudere completamente la leva.



- Tutti gli sganci rapidi devono essere fissati prima di partire.
- Dopo aver lasciato la bicicletta incustodita e prima di ogni partenza, verificare la corretta posizione di tutti gli sganci rapidi.
- Quando è chiusa, la leva di sgancio rapido deve essere stretta contro telaio, forcella e reggisella!



Oltre a chiudere a chiave la bicicletta pieghevole, anche le parti fissate con sganci rapidi devono essere attaccate, ad es. con un lucchetto a cavo. Ciò rende più difficile un eventuale furto delle parti.

## 1.2 Impostazione e regolazione successiva del giunto pieghevole sul telaio



Far verificare da un rivenditore specializzato FLYER la forza di bloccaggio del giunto pieghevole dopo 500 piegature o quando la forza di bloccaggio comincia ad allentarsi.



Forza di bloccaggio corretta del giunto pieghevole: 10kg/98,1N

## 1.3 Istruzioni pieghevoli della FLYER Upstreet2



Il sistema di propulsione deve essere sempre spento prima che venga iniziato il processo di piegatura.

Per piegare la FLYER Upstreet2 in modo facile e sicuro, occorre dotarla di bloccaggi rapidi in tutti i punti importanti.



Rimuovere la chiave dal lucchetto della batteria e della bicicletta prima di piegarla.



Aprire il cavalletto centrale della FLYER Upstreet2 affinché non cada sul motore in posizione piegata.



Portare le pedivelle in posizione orizzontale prima di piegare la bicicletta o posizionare il pedale sul lato sinistro completamente in basso.

1. Piegare prima i pedali della FLYER Upstreet2. A tale scopo fare pressione lateralmente sui pedali nella direzione della pedivella (1) e piegarli di 90° (2).

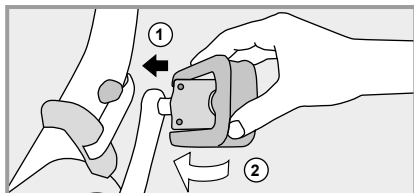

2. Posizionarsi sul lato sinistro della bicicletta. Aprire lo sgancio rapido della sella (1) e posizionare il reggisella completamente in basso (2).

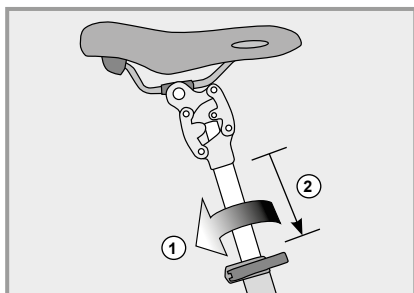

Richiudere lo sgancio rapido (3) affinché la sella resti in posizione.

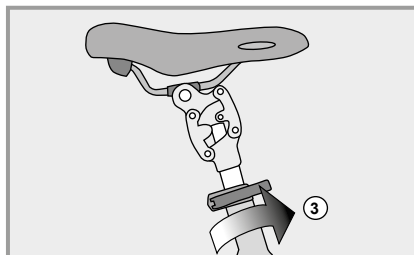

3. Sganciare la leva di sicurezza (1) dell'avancorpo pieghevole premendo sul pulsante rotondo di sgancio.

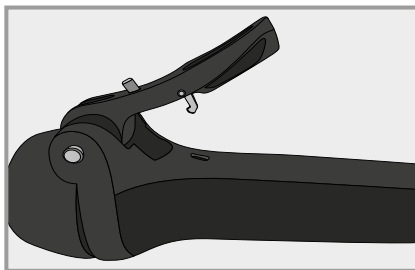

Piegare verso il basso l'avancorpo insieme al manubrio.

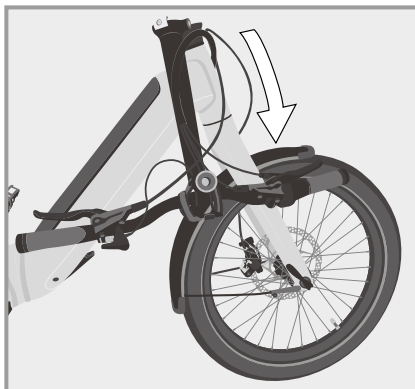
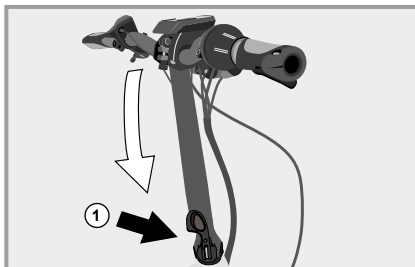

4. Sbloccare la leva di bloccaggio (2) spingendo la molla di sicurezza (3) verso l'alto.

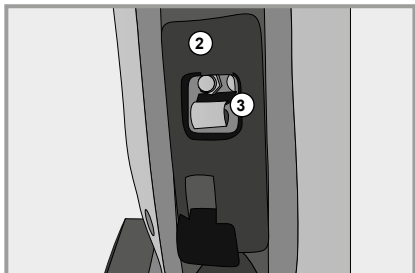

5. Spingere la leva di bloccaggio (2) completamente in basso affinché la chiusura viene sbloccata.



Piegare poi la parte anteriore del telaio verso sinistra (2).

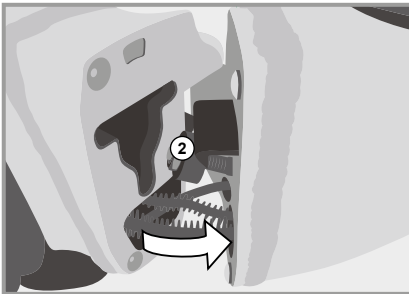

6. Muovere la parte anteriore contro la parte posteriore del telaio fino a innestare la sicura Klickfix sulla ruota anteriore (1) e su quella posteriore (2).

Chiusura a scatto Klickfix sulla forcella rigida (1)  
Perno di bloccaggio sulla parte posteriore (2)



Verificare che la sicura tra la forcella della ruota anteriore e la parte sinistra della forcella posteriore inferiore sia innestata completamente. Altrimenti la bicicletta pieghevole può aprirsi nel sollevarsi e causare lesioni.

7. Piegata correttamente, la FLYER deve avere il seguente aspetto:



Ripiegare il cavalletto prima del trasporto.

## 1.4 Apertura FLYER Upstreet2

Prima di iniziare ad aprire la FLYER Upstreet2, portare il cavalletto in basso e le pedivelle in posizione orizzontale oppure posizionare la pedivella sinistra completamente in basso.

1. Sganciare la sicura Klickfix premendo il meccanismo di sgancio rosso.

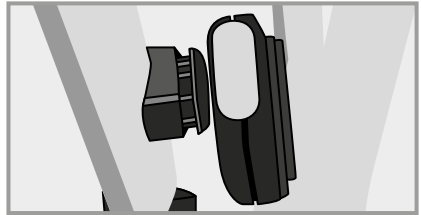

2. Spingere la leva di bloccaggio dello snodo del telaio verso il basso e separare la parte anteriore e quella posteriore del telaio fino a formare una linea retta e affinché le due parti non si muovono più.



3. Innestando la leva di bloccaggio (2) in alto, lo snodo del telaio si chiude.

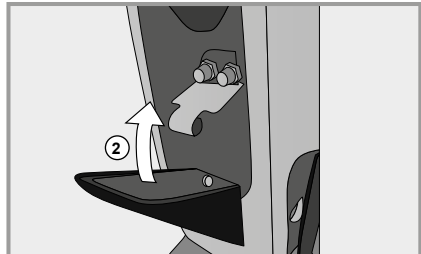

Afferrare la bicicletta per controllare che lo snodo del telaio sia correttamente innestato.



Verificare che la forza di serraggio sia corretta. In mancanza di forza di serraggio, rivolgersi immediatamente al proprio rivenditore specializzato FLYER per registrare la leva di bloccaggio. Verificare la posizione sicura della leva.

Piegare di nuovo l'avancorpo verso l'alto e bloccarlo con lo sgancio rapido.

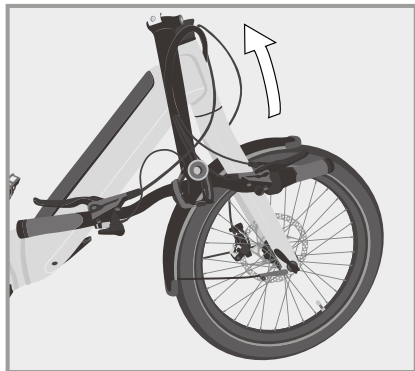

3. Aprire lo sgancio rapido del reggisella (1)

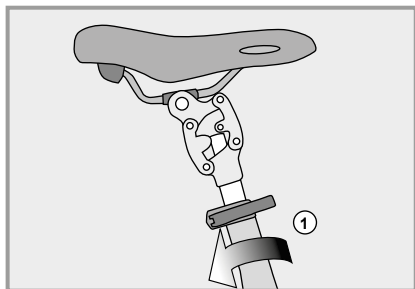

e tirare il reggisella dal piantone fino all'altezza desiderata (2). Richiudere quindi lo sgancio rapido (3) correttamente, affinché la sella resti in posizione.

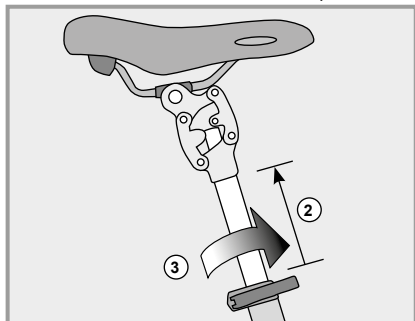

Sul reggisella è contrassegnato il punto massimo di estrazione dal telaio. Non estrarre mai il reggisella dal tubo del telaio oltre questa marcatura!

4. A questo punto aprire i pedali della FLYER Upstreet2. Ruotarli di 90° verso l'esterno (1). Estrarli leggermente verso l'esterno (2), fino a innestarli nella posizione di guida.

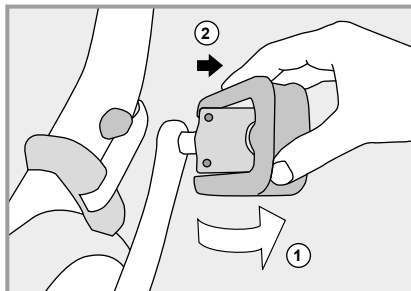

Verificare la chiusura corretta e sicura di tutti gli sganci rapidi e dei bloccaggi.



Ripiegare il cavalletto prima di iniziare a guidare!



Prima di ogni utilizzo, assicurarsi che la forza di serraggio del giunto pieghevole sia sufficiente secondo le indicazioni di cui al cap. 1.2 e assicurarsi che tutte le sicure siano chiuse correttamente. Durante la guida, il giunto pieghevole deve essere sempre assicurato e non può essere manipolato.



Far verificare regolarmente il bloccaggio pieghevole dal proprio rivenditore specializzato FLYER. Non girare autonomamente le viti di bloccaggio.



## FLYER UPSTREET 2

EN Bike folding instructions

# The FLYER e-bike and its components

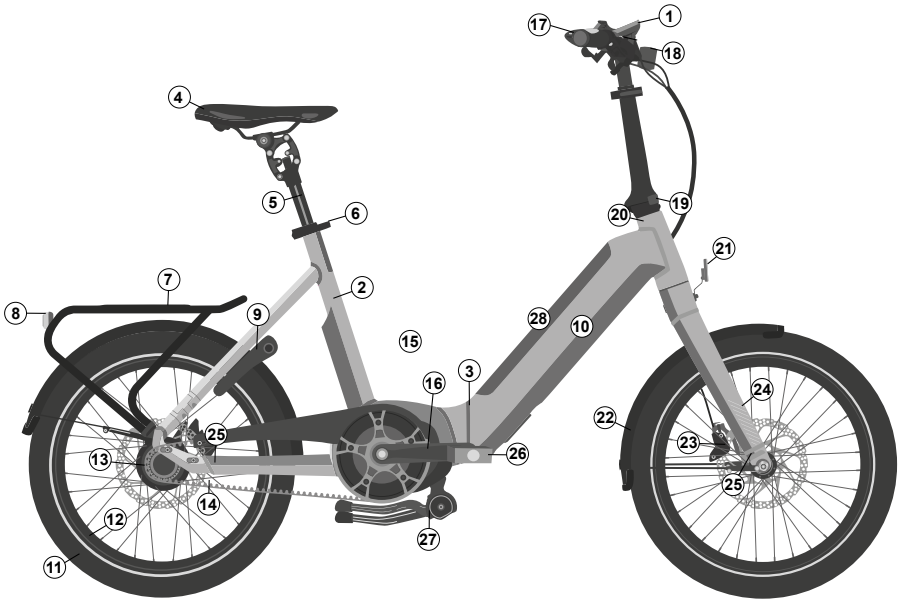

- ① Display
- ② Frame
- ③ Folding hinge with safety lever
- ④ Seat
- ⑤ Seat post
- ⑥ Quick release lever on the seat post
- ⑦ Rack
- ⑧ Rear light
- ⑨ Frame lock
- ⑩ Battery
- ⑪ Wheel
- ⑫ Rim
- ⑬ Hub
- ⑭ Chain/Belt
- ⑮ Motor (under the chain guard)
- ⑯ Crank
- ⑰ Handlebars
- ⑱ Headlight
- ⑲ Foldable stem
- ⑳ Headset
- ㉑ Reflector
- ㉒ Mudguard
- ㉓ Brake
- ㉔ Fork
- ㉕ Securing the bike in a folded state
- ㉖ Folding pedals
- ㉗ Bike stand
- ㉘ Bottle holder

# 1. Folding instructions for the FLYER Upstreet2

These folding instructions contain important information that tells you how to fold your new FLYER. They also provide you with safety tips and help prevent you harming people, objects and the environment. You should therefore keep these instructions in a safe place, always have them to hand and observe the pointers provided. Please provide these instructions with the FLYER when you lend it to other persons.

 Always make sure that your FLYER Upstreet2 is in a safe position when transported in a folded state. Especially when transporting your bike by public transport or car, you should make sure it cannot fall when the vehicle is in motion. You may need to secure it better or hold onto it firmly. If your bike falls over, important components may become damaged.

 You may only carry out maintenance or servicing work on the bike when the system is switched off.

## 1.1 Using quick releases

Quick releases are systems installed on the bicycle in place of bolted connections. They consist of two parts: the clamping lever, which provides the necessary clamping force, and the locking nut, which allows you to regulate the clamping force. You can change the setup of your quick release when the clamping lever is open.

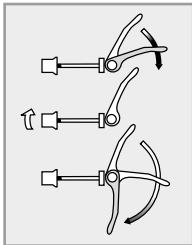

Loosening the Adjusting Nut

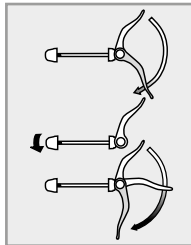

Tightening the Adjusting Nut

 You will know if the quick release and locking lever have been closed with the proper gripping force when you feel pressure half way through closing them. Just before it closes, you should have to apply extra force with the ball of your thumb to close the lever completely.



All quick release skewers must be firmly closed before you set off.

- Check all quick release fasteners for correct attachment if the vehicle was parked for a short time without supervision and before every ride.
- A closed quick release fastener must be folded close to the frame, fork or seat post.



In addition to closing the folding bike, you should also lock up the bike with a separate locking device, i.e. with a cable lock. By doing so, you will prevent your bike from being stolen.

EN

## 1.2 Adjusting and readjusting the frame's folding hinge



After 500 folds or when the gripping force decreases, let your FLYER retailer check the gripping force on the folding hinge.



Proper gripping force of the folding hinge: 10 kg/98.1 N

## 1.3 Folding instructions for the FLYER Upstreet2



The drive system must always be switched off before the folding procedure is started.

To make it easier and safer to fold your FLYER Upstreet2, the bike has been equipped with quick-release fasteners in all the most important places.



Before starting folding, remove the keys from the battery and bicycle locks.



Fold up the central kickstand of your FLYER Upstreet2 so that it cannot fall on the motor when the bike is folded.



Before starting folding, bring the cranks into a horizontal position or move the pedal on the left-hand side into its lowest position.

1. First, fold the pedals of your FLYER Upstreet2. To do this, press on the side of the pedals towards the crank (1) and fold them up through 90° (2).

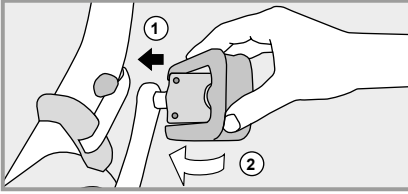

2. Stand on the left-hand side of the bike. Open the saddle quick-release tensioner (1) and press the seat post all the way down (2).

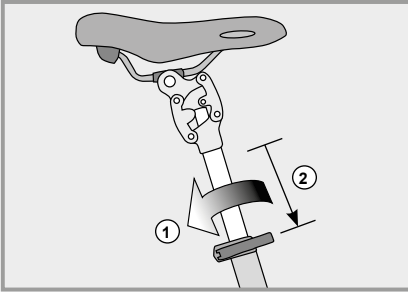

Close the quick-release tensioner again (3) to keep the saddle in this position.

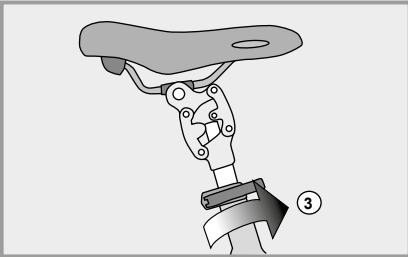

3. Unlock the safety lever (1) of the foldable stem by pressing down on the round unlocking button.

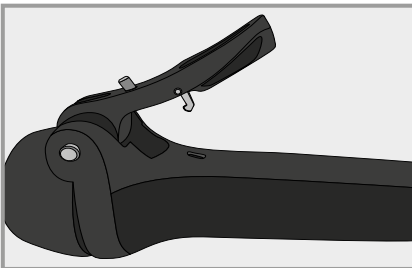

Fold the stem and handlebars down

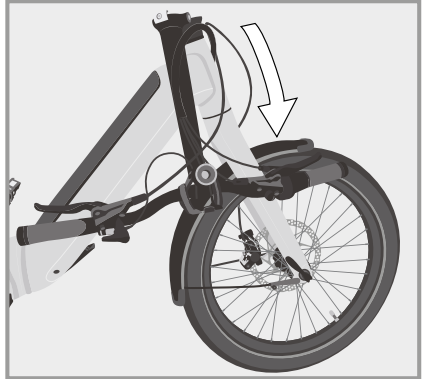
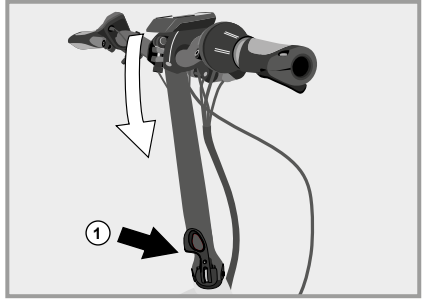

4. Unlock the locking lever (2) by pushing the retaining spring (3) upwards.

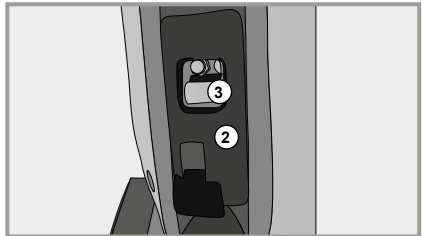

5. Press the locking lever (2) all the way down until the folding clasp unlocks.

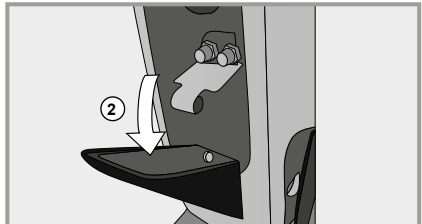

You should now be able to fold the front part of the frame to the left (2).

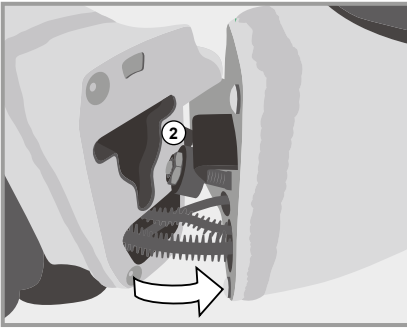

6. Now, unlock the locking lever (1) on the frame hinge with the aid of the retaining spring and press the locking lever all the way down until the catch is unlocked.

KLICKfix snap lock on rigid fork (1)  
KLICKfix catch pin on rear fork (2)

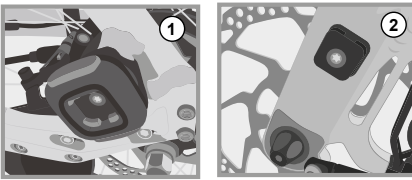

Make sure that the safety catch between the front wheel fork and the left chain stay is fully engaged. Otherwise, this can cause the folding bike to open when picked up and may cause injury.

7. If folded correctly, your FLYER should look like this:

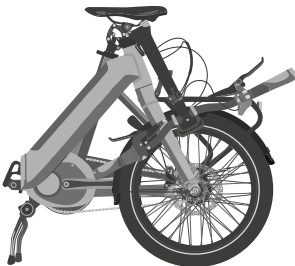

Fold up the central kickstand again before transporting the bike.

## 1.4 Unfolding the FLYER Upstreet2

Before you begin unfolding your FLYER Upstreet2, fold down the central kickstand and either position the cranks horizontally or bring the left crank all the way down.

1. Detach the KLICKfix folding clasp by pressing the red trigger mechanism.

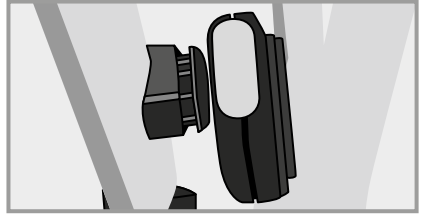

2. Press down the locking lever on the frame hinge and pull the front and back parts of the frame apart until they are in a straight line and cannot be moved any further.

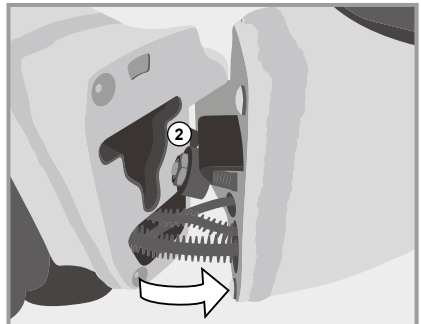

3. The frame hinge locks when the safety lever (2) latches in at the top.

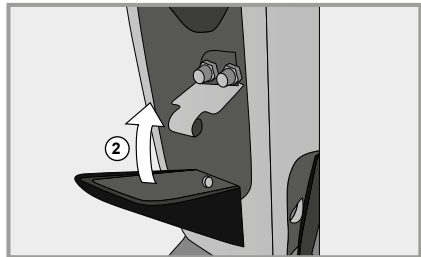

EN



Take hold of the frame hinge to verify that it is locked in place.



Make sure that there is sufficient gripping force. If the gripping force is insufficient, contact your FLYER specialist retailer immediately and have the locking lever adjusted. Make sure that the lever is securely fastened.

Then, unfold the stem upwards and lock it in place with the quick-release tensioner.

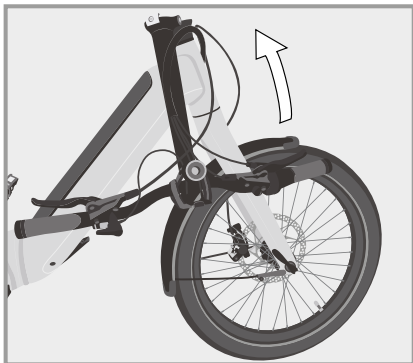

3. Open the seat post quick-release tensioner (1)

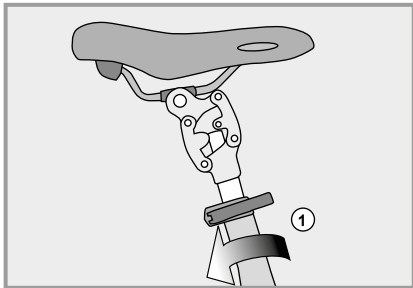

and pull the saddle post out of the seat tube until it reaches the desired height (2). Then correctly close the quick-release tensioner again (3) so that the saddle remains securely in position.

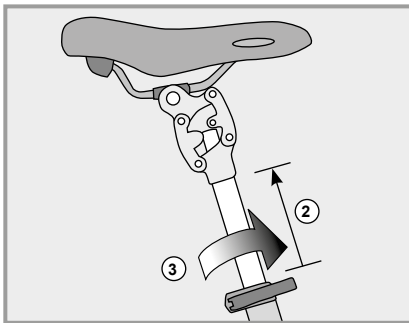

There are markings on the seat post which show how far it can be pulled out of the frame. Never pull the seat post beyond the maximum length marking.

4. Now unfold the pedals of your FLYER Upstreet2. Fold them outwards through 90° (1). Carefully pull the pedals outwards (2) until they latch into their riding position.

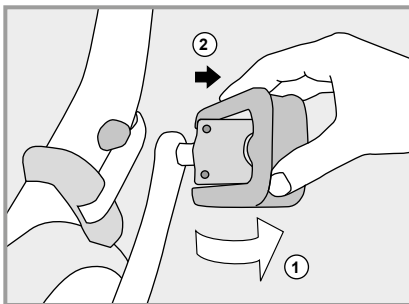

Make sure that all of the quick-release tensioners and fastening latches are correctly and securely fastened.



Before riding, fold up the central kickstand.



Before each trip, make sure that there is enough gripping force at the folding hinge as shown in chapter 1.2. In addition, make sure that all safety catches are correctly closed. When riding, the folding hinge must always be secured and must never be altered.



Have your FLYER specialist retailer regularly check the folding clasp. Do not turn the adjusting screws on your own.

SWISS PREMIUM E-BIKES

**FLYER**



## FLYER UPSTREET 2

NL Vouwinstructie

---

NL

# De FLYER en zijn onderdelen

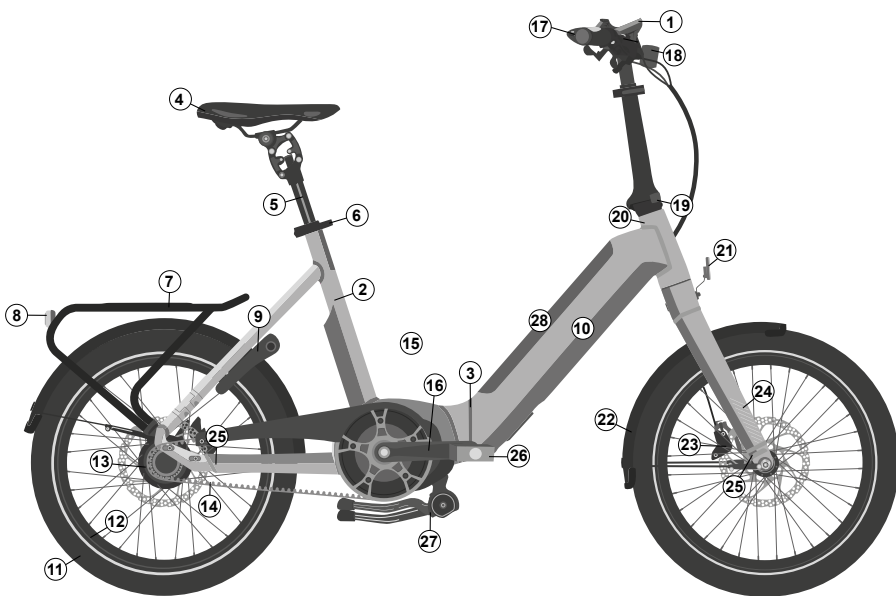

- |  |                                      |
|--|--------------------------------------|
| ① Display                                | ⑮ Motor (onder kettingkast)          |
| ② Frame                                  | ⑯ Krukas                             |
| ③ Vouwscharnier met vergrendelingshendel | ⑰ Stuur                              |
| ④ Zadel                                  | ⑱ Koplamp                            |
| ⑤ Zadelpen                               | ⑲ Inklapbare voorbouw                |
| ⑥ Zadelpensnelspanner                    | ⑳ Balhoofdstel                       |
| ⑦ Bagagedrager                           | ㉑ Reflector                          |
| ⑧ Achterlamp                             | ㉒ Spatbord                           |
| ⑨ Frameslot                              | ㉓ Rem                                |
| ⑩ Accu                                   | ㉔ Vork                               |
| ⑪ Wiel                                   | ㉕ Vergrendeling in gevouwen toestand |
| ⑫ Velgen                                 | ㉖ Vouwpedaal                         |
| ⑬ Naaf                                   | ㉗ Standaard                          |
| ⑭ Ketting/Riemaan                        | ㉘ Bidonhouder                        |

# 1. Vouwinstructie FLYER Upstreet2

Deze vouwinstructie bevat belangrijke informatie die u nodig hebt om het vouwen van uw nieuwe FLYER te oefenen, om bekend te raken met de veiligheidsaspecten ervan en om persoonlijk letsel, beschadiging van eigendommen en schade aan het milieu te voorkomen. Bewaar de gebruiksaanwijzing goed, houd deze binnen handbereik en neem de erin vermelde aanwijzingen in acht. Geef deze gebruiksaanwijzing mee als u uw FLYER aan anderen ter beschikking stelt.

**i** Let altijd op dat uw FLYER Upstreet2 stevig staat wanneer u hem in gevouwen toestand vervoert. Vooral wanneer u de fiets in het openbaar vervoer of een auto meeneemt, dient u erop te letten dat hij niet kan omvallen als het voertuig in beweging is. Zet de fiets eventueel met hulpmiddelen vast of houd hem zelf vast. Wanneer hij omvalt kunnen belangrijke onderdelen beschadigd raken.

**i** Onderhoudswerkzaamheden, servicebeurten en dergelijke mogen alleen worden uitgevoerd wanneer het systeem is uitgeschakeld.

## 1.1 Snelspanner bedienen

Snelspanners zijn voorzieningen die via een schroefverbinding onderdelen aan een fiets vastzetten. De bediening vindt via twee elementen plaats: met de snelspanhendel brengt u de noodzakelijke klemkracht aan, met de instelmoer regelt u hoe sterk deze worden aangeklemd. U zorgt voor deze instelling als de snelspanhendel geopend is.

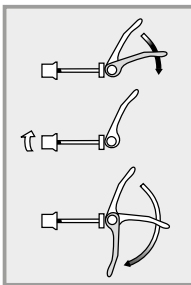

Instelbout vergrendelen

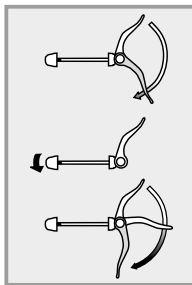

Instelbout aantrekken



De snelspanner en vergrendelingshendel sluiten met de juiste klemkracht wanneer er vanaf het midden van de totale hevelbeweging tegendruk is waar te nemen en aan het einde van de hevelbeweging de kracht van de handbal nodig is om de hendel helemaal te sluiten.



- Alle snelspanners moeten goed gesloten zijn, voor u gaat rijden.
- Controleer alle snelspanners op juiste positionering als het voertuig gedurende korte tijd zonder toezicht geparkerd wordt en voor elke tocht.
- In gesloten toestand moet de snelspanhendel dicht bij het frame, de voorvork of zadelpen liggen!



Naast het afsluiten van de vouwfiets met een slot moeten ook delen die met een snelspanner vastzitten apart, bijv. met een kabelslot, worden vastgemaakt. Zo kunt u diefstal van de delen bemoeilijken.

## 1.2 In- en afstellen van het vouwscharnier in het frame



Laat de klemkracht van het vouwscharnier na 500 keer opvouwen, of wanneer de klemkracht afneemt, controleren door een FLYER-dealer.



Juiste klemkracht van het vouwscharnier: 10 kg/98,1N

## 1.3 Vouwinstructie FLYER Upstreet2



Voordat u met het opvouwen begint, moet u altijd eerst het aandrijfsysteem uitschakelen.

Om uw FLYER Upstreet2 eenvoudig en veilig te kunnen opvouwen, is hij op alle belangrijke plaatsen uitgerust met snelsluitingen.





Verwijder voor het opvouwen de sleutel uit het accu- en fietsslot.



Klap de middenstandaard van uw FLYER Upstreet2 omhoog, zodat deze in gevouwen toestand niet op de motor kan vallen.



Zet de trapperarmen voor het opvouwen horizontaal of zet de linkertrapper helemaal naar beneden.

1. Klap eerst de trappers van de FLYER Upstreet2 in. Druk daarvoor vanaf de zijkant tegen de trappers in de richting van de trapperarm (1) en klap ze vervolgens 90° om (2).

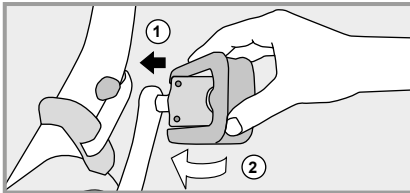

2. Ga aan de linkerkant van de fiets staan. Open de snelspanner van de zadelpen (1) en laat de zadelpen helemaal naar beneden zakken (2).

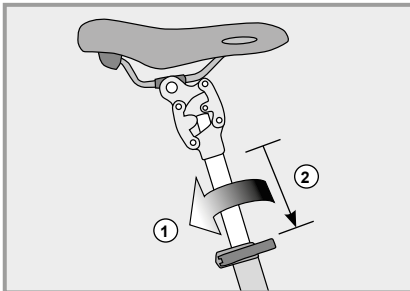

Sluit de snelspanner weer (3) om het zadel vast te zetten.

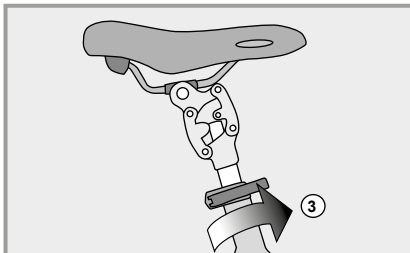

3. Druk op de ronde ontgrendelingsknop om de borghendel (1) van de inklapbare voorbouw te ontgrendelen.

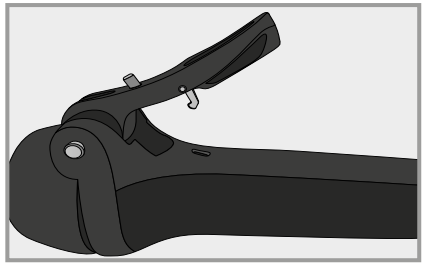

Klap de voorbouw samen met het stuur omlaag.  
Fold the stem and handlebars down

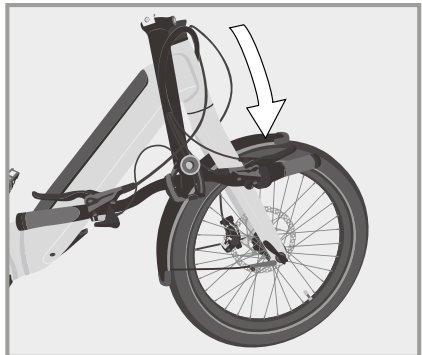
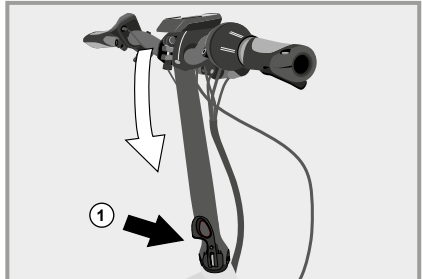

4. Druk de borgveer (3) omhoog om de vergrendelingshendel (2) te ontgrendelen.

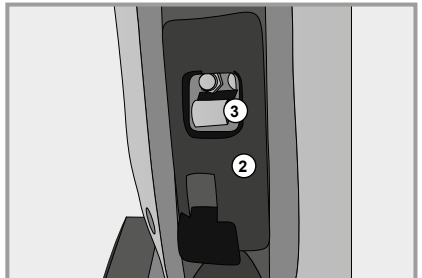

5. Druk de vergrendelingshendel (2) volledig naar onderen totdat het vouwmechanisme wordt ontgrendeld.



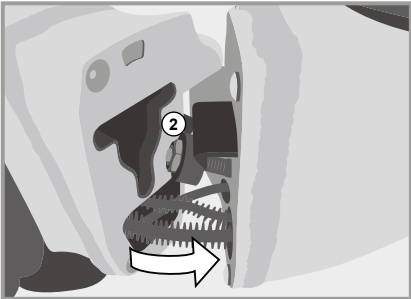

Daarna kunt u het voorste deel van het frame naar links klappen (2).

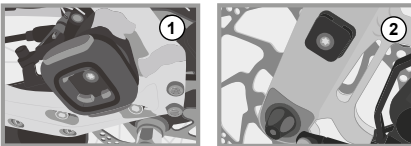

6. Beweeg het voorste en achterste deel van het frame zo ver naar elkaar toe dat de Klickfix-sluiting op het voor- (1) en achterwiel (2) vastklikt.

Klickfix-kliksluiting op voorvork (1)  
Klickfix-klem op de achterbouw (2)



-  Controleer of de beveiliging tussen de voorvork en de linkerbuis van de achtervork volledig is vergrendeld. Indien u dit nalaat kan de vouwfiets bij het optillen uitklappen, wat letsel tot gevolg kan hebben.

7. Zo hoort uw FLYER eruit te zien als hij correct is opgevouwen:

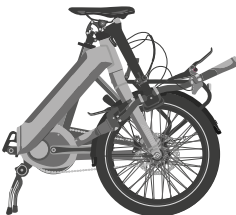

Klap voordat de fiets wordt vervoerd de

## 1.4 FLYER Upstreet2 uitvouwen

Voordat u met het uitvouwen van de FLYER Upstreet2 begint, moet u eerst de middenstandaard omlaag klappen en de trapperarmen horizontaal plaatsen of de linkertrapper helemaal naar beneden zetten.

1. Ontgrendel de Klickfix-sluiting door op de rode ontgrendelingsknop te drukken.

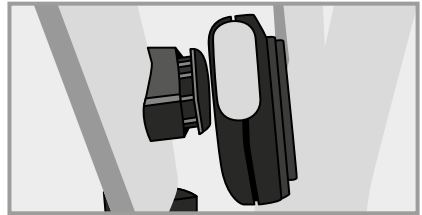

2. Duw nu de vergrendelingshendel van het framescharnier naar beneden en beweeg het voorste en het achterste deel van het frame uit elkaar tot ze in lijn van elkaar staan en niet verder kunnen worden bewogen.

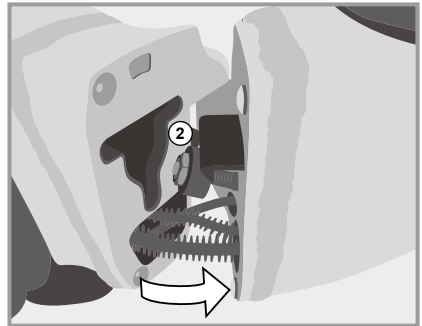

3. Het framescharnier sluit, waarbij de vergrendelingshendel (2) aan de bovenzijde vastklikt.



Controleer met een klemgreep of het framescharnier daadwerkelijk is vergrendeld.



Let erop dat de klemkracht voldoende is. Breng de fiets bij onvoldoende klemkracht onmiddellijk naar uw FLYER-dealer om de vergrendelingshendel te laten nastellen. Controleer of de hendel stevig vastzit.

Klap de voorbouw weer naar boven en zet deze vast met de snelspanner.

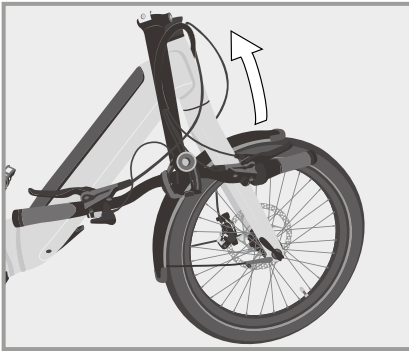

3. Open de snelspanner van de zadelpen (1)

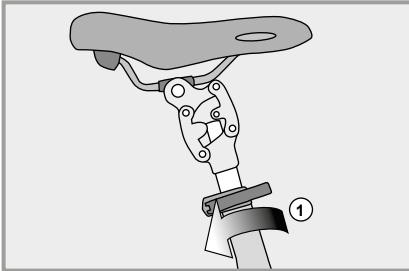

en trek de zadelpen tot de gewenste hoogte uit de zitbuis (2). Sluit de snelspanner weer (3) om het zadel vast te zetten.

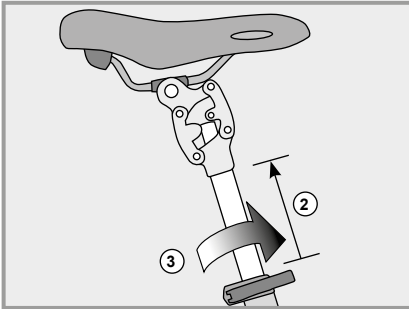

Op de zadelpen staat aangegeven hoe ver deze maximaal uit het frame mag worden getrokken. Trek de zadelpen nooit verder uit dan tot de markering!

4. Klap nu de trappers van de FLYER Upstreet2 weer uit. Draai ze 90 ° naar buiten (1). Trek ze rustig naar buiten (2), totdat ze in de goede positie vastklikken.

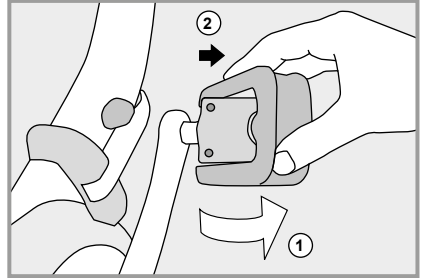

Controleer of alle snelspanners en sluitingen goed en veilig vast zitten.



Klap voordat u gaat fietsen de middenstandaard weer in!



Controleer voor elke rit of de klemkracht van het framescharnier voldoende is volgens de informatie in hoofdstuk 1.2 en controleer of alle sluitingen goed zijn vergrendeld. Tijdens het rijden moet het framescharnier altijd vergrendeld zijn en mogen geen pogingen worden gedaan om het te openen.



Laat het vouwmechanisme regelmatig door uw FLYER-dealer controleren. Draai niet zelf aan de sluitschroeven.

## IMPRESSUM / LEGAL DISCLOSURE

### Verantwortlich für Inhalt und Abbildungen

**FLYER AG**

Schwende 1

CH-4950 Huttwil

T +41 62 959 55 55

© Vervielfältigung, Nachdruck und Übersetzung sowie jegliche wirtschaftliche Nutzung sind (auch auszugsweise, in gedruckter oder elektronischer Form) nur mit vorheriger schriftlicher Genehmigung durch die FLYER AG zulässig.

Bitte beachten Sie, dass alle Anleitungen ohne vorherige Bekanntgabe zu Verbesserungszwecken geändert werden können.

Regelmässige technische Aktualisierungen finden Sie unter [www.flyer-bikes.com](http://www.flyer-bikes.com).

**DE** Falanleitung

**FR** Procédure de pliage

**IT** Istruzioni pieghevoli

**EN** Bike folding instructions

**NL** Vouwinstructie



---

Ihr FLYER Fachhändler



[flyer-bikes.com/manuals](https://flyer-bikes.com/manuals)